

Enhancing Microgrid Efficiency: AI-Based Energy Management Systems and Electrical Topologies

Abhishek Kumar Mishra, MTech Scholar, Bhopal Institute of Research and Technology Bhopal (MP)

Abhishek Dubey, Professor, Bhopal Institute of Research and Technology Bhopal (MP)

Abstract—The energy management approaches for microgrid (MG) systems have received a lot of attention in recent years. The goal of integrating an Energy Management System (EMS) into MG and/or buildings is to increase energy efficiency and save energy costs. This page provides an overview of several MG electrical topologies, as well as some prominent MG concepts that incorporate EMS. Some AI-based (AI) methods in the EMS sector, such as Artificial Neural Networks (ANN), Fuzzy Logic (FL), Machine Learning (ML), and Expert Systems (ES), are also investigated.

Keywords—Microgrid, DC MG, AC MG, Hybrid MG, EMS, Artificial Intelligence, Machine learning, Fuzzy Logic, Expert system, Neural Networks.

I. INTRODUCTION

The description given by the specialists in the field of MG [1,2,3] is ample. It defines the MG rightly, as an aggregation of sources and loads. The MG system concerns, allow many researchers to develop many technologies of Energy Management System (EMS) [4, 5]. They have a common goal: to continuously meet the needs of the facility, ensure maximum use of the energy produced, minimize the cost of this energy and reduce storage [4,6,7]. The impact of this technology not only in terms of energy efficiency and cost but also on the environmental aspect [8,9,10].

In the recent years, the Energy Management System (EMS) and Artificial Intelligence (AI) have become extremely important.

In recent years, the Artificial Intelligence (AI) and Energy Management System (EMS) have become extremely important. To mitigate climate change and increase energy efficiency, researchers have studied a wider range of solutions like Microgrid (MG), Smart Grid (SG), storage system, Intelligent Energy Management System (IEMS) and soon.

In the concern of EMS, several methods and strategies have been developed. The author in [5] summarizes different energy management methods on Microgrids. An EMS is usually integrated within an MG to manage efficiently the intermittent renewable resources using a control system concept [11].

This paper aims to summarize some approaches used for energy management in Microgrid systems and their diverse architectures. So, the MG system is briefly introduced in

Section 2 and the MG electrical architecture is depicted in Section 3. The first part of Section 4 deals with some energy management approaches used both in standalone and connected MG. The second part represents, the different technologies and some Artificial Intelligence (AI) methods in the EMS domain. The conclusion and discussion are given in the last section.

II. MICROGRID SYSTEM

The authors in [12] defined an MG as a low-voltage distribution system connected to modular generation systems. In [13], the authors refer the MG as an integrated system in which Distributed Energy Resources (DERs) create a grid that provides energy to distributed loads.

An MG system is composed of one or more production sources, these sources are based on Renewable Energies (RE) such as Photovoltaic Panels (PV) and Wind Turbines (WT). Also, we can find a conventional sources like batteries for energy storage [14, 15, 16]. However, the major obstacle to the development of the MG system, based on Renewable Energy (RE), is their intermittency due to the meteorological parameters, they depend on heavily [16]. The production sources are also coupled with an external power source, public electricity networks or diesel generator [17]. The use of this conventional source is one of the solutions that can limit this intermittence [9, 18, 19, 20].

Indeed, integrating these solutions helps to avoid the mentioned drawbacks of renewable energy [21, 22] and permits the continuity of service when the meteorological parameters do not allow energy production or the storage system is not sufficient, but it requires a big investment to cover the demand [18, 20].

An MG has two operating modes: an autonomous mode (OFFGRID) or standalone MG and a connected mode to the network (ONGRID) [12, 16, 23, 24]. In stand-alone mode, the MG can be unrelated from the main grid due a geographic isolation or to the failure of the main grid. When the power produced by the RE sources is less than the demand, the battery supplies the deficit [9], in the case where both RE and battery are not sufficient, the diesel generator operates to supply the demand. The MG considered the grid-connected mode as an integral part of the power system, when the production sources are less than the demand, then it is switched to the public grid network [25].

III. ELECTRICAL ARCHITECTURE OF AN MGSYSTEM

In[25],theauthorsdescribeaMGsystemasanelectrical energy architecture that aggregate sources, loads andstorage which can be controlled by anEMS.

Moreover, the MG electrical architecture can be the one from the three following types: Direct Current (DC) MG, AlternativeCurrent(AC)MGandHybridAC/DCMicrogrid [21,23,26].

A. Alternative Current Microgrid (ACMG)

The Fig. 1 depicts an Alternative Current (AC) MG Electrical architecture. The concept of AC MG requires that the AC sources supply AC loads like microwave oven, hairdryer, common lighting, Dishwasher, Refrigerator, Washingmachineandso.InthecaseofsupplyingDCloads, which exist in the majority of buildings, a bi-directional inverterisusedtofeedtheseloadsthataredifferentfromthe source.

The paper [24] gives a review of AC MG components, thataredifferentfromeachother,butoneormore renewable sources are important in an AC MGsystem.

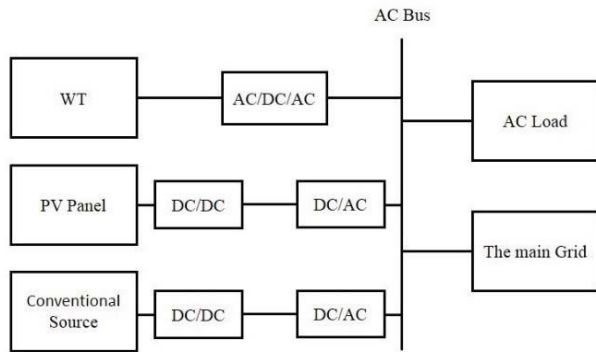

Fig. 1. Alternative Current (AC) MG Electrical architecture.

B. Direct Current Microgrid (DC MG)

The Fig. 2 illustrates a typical diagram of the DC architecture configuration of an MG. The DC MG is the

conceptfacingthedemandoftheusersaswellasmostofthe loads are DC loads such as light-emitting diodes (LEDs), laptopbatteries;cellphonebatteries,Wirelessinternetrouter and so.

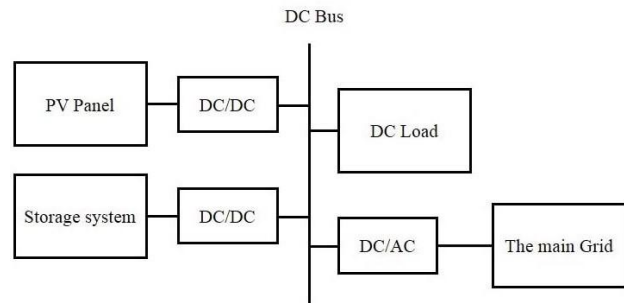

Fig. 2. Direct Current (DC) MG Electrical architecture

In [16] the authors propose a basic structure of the DC standalone MG. This structure consists of PV panels, WT, battery storage and fuel cell.

In the literature, there are several structures from which the author in [24] gives a general overview of different structures and components used in many kinds of research. The DC MG does not have a reactive power, it is much simplerunlikeACMG[24].Additionally,theauthorsin[18] refer to AC and DC loads and the value-added if DC loads are fed directly from the PV source that is already in DC mode.

In[27],theauthorspropose thattheDCelectricitysources shoulddirectlysupplyDCloads.For more renewable energy efficiency, a bi-directional inverter is introduced to control and limit DC-grid voltage within a givenrange.

Table 1 gives a review in terms of the advantages and disadvantages of DC and AC electrical architecture. In order to reducetheinstallationcostsforanMG,itissuitabletofeed it with a high number of AC loads. For offices and data center, DC Microgrids are more appropriate, they include more DC loads[13].

TABLE I. ADVANTAGE AND DISADVANTAGE OF DC AND AC ELECTRICAL ARCHITECTURE.

Type	DC architecture	AC architecture
Advantage [26, 28, 29]	<p>More efficient: It can transmit more power with the minimum losses over long distances.</p> <p>Lower cost: Higher efficiency means lower transmission cost</p> <p>Improved reliability: High-voltage direct current (HVDC) transmission can improve systemstability.</p> <p>Compatibility: Modern electrical loads and renewable energy sources are DC.</p> <p>Stability: The only electrical quantity that needs to be supported is the DC bus voltage.</p>	<p>Simplicity: at the level of generation, transmission and distribution.</p> <p>Availability: The majority of electrical equipment used in the market is compatible to AC.</p> <p>Simplicity: AC power can intensify very easily and efficiently.</p> <p>Safety: CAs has been shown to be safer for humans.</p> <p>Compatibility: It is compatible with the existing public network.</p>
Disadvantage [26, 28]	<p>DC circuits are not compatible with electrical safety tools.</p> <p>Existing building codes and standards are specific to alternating current.</p> <p>DC power has different insulation, safety requirements due to the nature of DC power.</p>	<p>The AC transmission line generates a lot of electrical losses.</p> <p>Unstable, problem of the reactive power.</p>

C. Hybrid micro-grid AC /DC

The Hybrid AC/DC Microgrid combines both the AC and the DC concepts. Fig. 3 shows a typical example of a Hybrid architecture that contains green sources, battery, AC and DC loads.

However, it exists a multiple presentations of Hybrid concepts in terms of component definition and the level of the adopted electrical architecture [12,30].

The authors in [31] consider an isolated hybrid MG where every DC source is coupled with DC loads and AC sources with AC loads. The same concepts are defined in [32] whereas generated power is swapped among both AC and DC sides utilizing a bidirectional mode converter. In the same reference the authors give also a review of MG technologies.

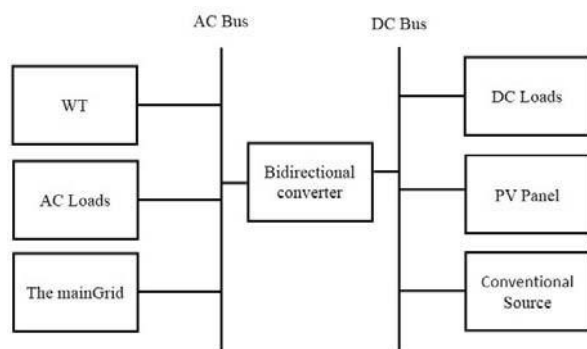

Fig. 3. Hybrid AC/DC Microgrid

In the few next decades, the AC Network is expected to be dominant due to the existing infrastructure [26]. But the hybrid concept will be more popular in the next few years for the following reasons [26]:

- The loads evolution from the AC to DC concept.
- The integration of RE sources and electric vehicles.

Also, the authors in [33] also summarize the advantages which help to choose the Hybrid concepts solution. From these advantages we can mention:

- The elimination of unnecessary multi conversion processes.
- The connection of all DC loads to the DC side will facilitate the control injections into the AC side through the main converters, thus guaranteeing high-quality AC in the grid.

IV. ENERGY MANAGEMENT SYSTEM TECHNOLOGIES AND METHODS

The principal function of the EMS is to reduce energy consumption using smart devices, to improve energy efficiency and customer comfort. In a building, it is necessary to control and optimize the energy use. So, the integration of an EMS is needed.

The authors in [34] consider that home energy management systems make residential customers aware of energy efficiency, comfort and support the energy system.

Indeed, the energy management systems based on historical data, statistical methods, forecasting techniques,

and load estimation will be most used in the future, owing to the growing uncertainties in future residential energy profiles and appliance types.

According to [35], the real-time energy management of a building can reduce the energy bills and then the primary energy consumption. The authors in [36] present an innovative approach to achieve energy management in the zero-energy building using smart load devices.

The use of intelligent energy management is important in an MG system to ensure the optimal energy consumed and reduce the cost. This need is necessary both for the stand-alone/OFF GRID systems and connected ones.

A. Energy Management System (EMS)

This section reviews the various EMS approaches used in stand-alone MG and grid-connected MG. Table 2 summarizes the research done in the field of EMS in different MG types. It describes the use of energy management in several domains.

In the literature, many parameters can contribute to the operation of an MG system such as the size of production source, storage and diesel generator. Certainly, a good energy management provides an efficient energy source, thus a low cost or an important Return on Investment (ROI), and decrease in CO₂ emission results. Table 2 summarizes some different MG concepts using the EMS, like the stand-alone MG, the main connected Grid and Electric vehicles.

B. EMS Technologies and methods

In many researches, some methods and technologies in the field of EMS are used. The authors in [6] investigated an application of a multi-agent system for cyber-enabled energy management of building structures.

In [41] authors propose a renewable generation forecast strategy. The grid compensates, at any times, the energy imbalance, whereas the battery is used to smooth daily fluctuations and drift between the measured and forecasted energy. In [5], authors presented several approaches on the techniques and methods used by researchers for EMS. Such as genetic algorithm (GA), Differential Evolution (DE), neural network, fuzzy logic, and Neuro-fuzzy, and so.

In [43], the Online learning is also used to adapt long term changes. Also, different tools have been used in ML, including ANN, Logistic Regression (LR), Deep Learning (DL) combined with time series, Support Vector Regression (SVR), Regression Tree (RT) and so.

Authors in [25] gave a short outline for the use of the FL to perform an EMS and present a design of a low complexity FL Controller for a residential grid-connected MGEMS.

A review on the applications of ANN in the field of energy, especially for predicting the performance of solid desiccant cooling systems, is presented in [44].

[45] summarizes the machine learning techniques and models utilized for building energy forecasting and benchmarking to indicate the advantages and drawbacks of each model. Also, this section also discusses the advantages

and drawbacks of some technologies and methods of Artificial Intelligence (AI) in the EMS field. Such as ArtificialNeuralNetworks(ANN)[46,47],FuzzyLogic(FL)

[47], Machine Learning (ML) [43] and Expert System (ES) [48,49]. Table 3 depicts some advantages and disadvantages of this technologies.

TABLE II. DIFFERENT MG CONCEPTS USING EMS.

Domain	Reference	Description of the use the energy management
Stand Alone MG	[37]	The author proposed a techno-economic analysis and they developed a hybrid system design that include PV panels, battery system and microturbine as a backup source in Palestine.
	[38]	It presents a hybrid autonomous energy system using hydrogen storage to meet the load need.
	[39]	A climate forecast predictive model control (MPC) was applied to an energy management analysis in an islanded domestic system.
	[40]	A battery management strategy was presented for charging and discharging batteries in a hybrid renewable energy system in order to manage the flow of energy between the different system components.
MG Connected to the maingrid	[41]	The author presents an energy management strategy for MG consisting of PV, WT and battery linked to the Grid.
	[8]	The author studies an energy management strategy adopted by HOMER was followed to execute the simulations.
	[25]	This paper reviews several EMS strategies based on FLC.
Electrical vehicles	[10]	This paper studied a collaborative decision model to optimize flow of electricity in commercial buildings, charging stations of Electric Vehicle (EV) and Grid under the uncertainty of energydemand
	[42]	A genetic algorithm can be applied to optimize the size of a hybrid photovoltaic/ battery system connected to the Grid in conjunction with a home EMS in different charging/discharging scenarios of a plug-in electric vehicle.

TABLE III. ADVANTAGES AND DISADVANTAGES OF EMS METHODS.

Domain	Reference	ADVANTAGE	DISADVANTAGE
Expert System	[48,49,50]	Program development flexibility. Superior problem solving. Reliability and Availability. Work with incomplete information. Fast response and Consistency. Combined knowledge.	High development costs. Only work well in narrow domains. Not all problems are suitable. Probable system complexity explosion due to problem size and consequences of actions.
Machine learning	[43,45]	Flexible with different tools. Self-learning/modifying and Intelligent decisions. Low cost and Easy installation. Privacy protection. Reliability and Availability.	Need a lot of labeled data. Works with continuous loss functions. Large data requirements.
Artificial Neural Networks	[44,45,46, 47]	Self-learning and Continuity of service. Flexibility and compatibility with other application. Speed and Simplicity of implementation Attractive attributes of identification and non-linear control. Appropriate for non-mathematical models. Capable to manage abundant number of data and input variables.	The functioning of the neural network needs training. Takes a long time to process the large neural network. Spending a lot of time for offline training. Quality predictions need a lot of data.
Fuzzy logic	[25,47,51]	Intuitive design model. Similar to human reasoning. No mathematical modeling is required. Rules and functions. Rapid operation. The control action is proved by the rules.	Stability is not assured. Obligatory attention for the control of critical systems The lower speed and slower run time. Lack of response in real time. Not able to receiving feedback for implementation of learning strategy. Limited number of input variables usage. Incapability to advance optimal fuzzy rules number and determine the membership function parameters.

V. CONCLUSION

In this paper, MG overview architecture is presented and discussed, as well as a summarized investigation on the AC-DC bus architecture advantages and disadvantages.

Hence, the EMS utilization in MG is becoming increasingly widespread. Likewise, many research works provide some energy management systems such as ML, FL, ES and ANN in order to reduce the electricity cost and to

support the trend towards a more sustainable and reliable green energy suppliers.

Further studies, in literature, prove that the ML approach is the most used to obtain efficient results, with a low cost, flexibility, reliability, availability and so. Moreover, the ML canbeextendedanOnlinelearningforlongtermchangesfor large-scaledeployments.

REFERENCES

- [1] Silva WWAG, Study of the application of bidirectional dual active bridge converters in dc nanogrid energy storage systems, Brazilian power electronics conference, 609714, IEEE 2013, <http://dx.doi.org/10.1109/COBEP.2013.6785178>.
- [2] Xuan Zhu, Past, today and future development of micro-grids in China, Renewable and Sustainable Energy Reviews 42 (2015) 1453-1463, <http://dx.doi.org/10.1016/j.rser.2014.11.032>.
- [3] L. Mariam, M. Basu and M. Conlon A review of existing microgrid architectures, Journal of Engineering, vol. 2013, pp.1-8, <http://dx.doi.org/10.1155/2013/937614>.
- [4] Zhao, Peng, et al. « An Energy Management System for Building Structures Using a Multi-Agent Decision-Making Control Methodology ». IEEE Transactions on Industry Applications, vol. 49, no 1, janvier 2013, p. 322-30. Doi: 10.1109/TIA.2012.2229682.
- [5] Olatomiwa, Lanre, et al. « Energy Management Strategies in Hybrid Renewable Energy Systems: A Review ». Renewable and Sustainable Energy Reviews, vol. 62, septembre 2016, p. 821-35. Doi: 10.1016/j.rser.2016.05.040.
- [6] Moehrlen, Corinna, et Jess U. Jørgensen. Reserve Forecasting for Enhanced Renewable Energy Management. 2014. Doi: 10.13140/2.1.1935.2647.
- [7] Xiang, Yue, et al. « Robust Energy Management of Microgrid With Uncertain Renewable Generation and Load ». IEEE Transactions on Smart Grid, 2015, p. 1-1. Doi: 10.1109/TSG.2014.2385801.
- [8] Kim, Heetae, et al. « Optimal Green Energy Management in Jeju, South Korea – On-Grid and off-Grid Electrification ». Renewable Energy, vol. 69, septembre 2014, p. 123-33. Doi: 10.1016/j.renene.2014.03.004.
- [9] Abdulkarim, Abubakar, et al. « Effects of PV and Battery Storage Technologies on the Optimal Sizing of Renewable Energy Microgrid ». ELEKTRIKA - Journal of Electrical Engineering, vol. 17, no 1, avril 2018, p. 1-8. Doi: 10.11113/elektrika.v17n1.49.
- [10] Qi, Jin, et al. « Collaborative Energy Management Optimization Towards Green Energy Local Area Network ». IEEE Transactions on Industrial Informatics, 2018, p. 1-1. Doi: 10.1109/TII.2018.2796021.
- [11] Kowalczyk, A.; Adrian, W. Microgrid Energy Management System. In Proceedings of the 2016 21st International Conference on Methods and Models in Automation and Robotics (MMAR), Miedzyzdroje, Poland, 29 August–1 September 2016; pp.157–162.
- [12] Kaur, Amdeep, et al. « A Review on Microgrid Central Controller ». Renewable and Sustainable Energy Reviews, vol. 55, mars 2016, p. 338-45. DOI.org, doi: 10.1016/j.rser.2015.10.141.
- [13] Planas, Estefanía, et al. « AC and DC Technology in Microgrids: A Review ». Renewable and Sustainable Energy Reviews, vol. 43, mars 2015, p. 726-49. DOI.org, doi: 10.1016/j.rser.2014.11.067.
- [14] Mariam, Lubna, et al. « A Review of Existing Microgrid Architectures ». Journal of Engineering, vol. 2013, 2013, p. 1-8. Doi: 10.1155/2013/937614.
- [15] Parhizi, Sina, et al. « State of the Art in Research on Microgrids: A Review ». IEEE Access, vol. 3, 2015, p. 890-925. Doi: 10.1109/ACCESS.2015.2443119.
- [16] Al-Sakkaf, Shehab, et al. « An Energy Management System for Residential Autonomous DC Microgrid Using Optimized Fuzzy Logic Controller Considering Economic Dispatch ». Energies, vol. 12, no 8, avril 2019, p. 1457. DOI.org, doi: 10.3390/en12081457.
- [17] Hirsch, A.; Parag, Y.; Guerrero, J. Microgrids: A Review of Technologies, Key Drivers, and Outstanding Issues. Renew. Sustain. Energy Rev. 2018, 90, 402–411.
- [18] Salas, V. « Stand-Alone Photovoltaic Systems ». The Performance of Photovoltaic (PV) Systems, Elsevier, 2017, p. 251-96. DOI.org, doi: 10.1016/B978-1-78242-336-2.00009-4.
- [19] Swaminathan Ganesan, Ramesh V, Umashankar S. « Hybrid Control of Microgrid with PV, Diesel Generator and BESS ». INTERNATIONAL JOURNAL OF RENEWABLE ENERGY RESEARCH Vol.7, No.3, 2017.
- [20] Mansour Alramlawi, Aouss Gabash, Erfan Mohagheghi, PuLi. « Optimal Operation of PV-Battery-Diesel MicroGrid for Industrial Loads Under Grid Blackouts » IEEE International Conference on Environment and Electrical Engineering (12-15 June 2018, Palermo, Italy).
- [21] Ould Bilal, B., et al. « Optimal Design of a Hybrid Solar–Wind–Battery System Using the Minimization of the Annualized Cost System and the Minimization of the Loss of Power Supply Probability (LPS) ». Renewable Energy, vol. 35, no 10, octobre 2010, p. 2388-90. Doi: 10.1016/j.renene.2010.03.004.
- [22] Weniger, Johannes, et al. « Sizing of Residential PV Battery Systems ». Energy Procedia, vol. 46, 2014, p. 78-87. Doi: 10.1016/j.egypro.2014.01.160.
- [23] Ahmed, Mohamed, et al. « Communication Network Architectures for Smart-House with Renewable Energy Resources ». Energies, vol. 8, no 8, août 2015, p. 8716-35. Doi: 10.3390/en8088716.
- [24] Justo, Jackson John, et al. « AC-Microgrids versus DC-Microgrids with Distributed Energy Resources: A Review ». Renewable and Sustainable Energy Reviews, vol. 24, août 2013, p. 387-405. DOI.org, doi: 10.1016/j.rser.2013.03.067.
- [25] Arcos-Aviles, Diego, et al. « A Review of Fuzzy-Based Residential Grid-Connected Microgrid Energy Management Strategies for Grid Power Profile Smoothing ». Energy Sustainability in Built and Urban Environments, édité par Emilia Motoasca et al., Springer Singapore, 2019, p. 165-99. DOI.org, doi: 10.1007/978-981-13-3284-5_8.
- [26] Salmasi, Farzad Rajaei, et Mehdi Hosseinzadeh. « Power Management of an Isolated Hybrid AC/DC Micro-Grid with Fuzzy Control of Battery Banks ». IET Renewable Power Generation, vol. 9, no 5, juillet 2015, p. 484-93. DOI.org, doi: 10.1049/iet-rpg.2014.0271.
- [27] Chen, Y.-K.; Wu, Y.-C.; Song, C.-C.; Chen, Y.-S. Design and Implementation of Energy Management System With Fuzzy Control for DC Microgrid Systems. IEEE Trans. Power Electron. 2013, 28, 1563–1570.
- [28] Glasgo, Brock, et al. « How Much Electricity Can We Save by Using Direct Current Circuits in Homes? Understanding the Potential for Electricity Savings and Assessing Feasibility of a Transition towards DC Powered Buildings ». Applied Energy, vol. 180, octobre 2016, p. 66-75. Doi: 10.1016/j.apenergy.2016.07.036.
- [29] What advantages does an alternating current have over a direct current? - Quora. https://www.quora.com/What-advantages-does-an-alternating-current-have-over-a-direct-current?redirected_qid=1108361#.
- [30] Khan, Shahzad, et al. « Artificial intelligence framework for smart city microgrids: State of the art, challenges, and opportunities ». 2018 21st International Conference on Fog and Mobile Edge Computing (FMEC), IEEE, 2018, p. 283-88. DOI.org, doi: 10.1109/FMEC.2018.8364080.
- [31] Indragandhi, V.; Logesh, R.; Subramaniaswamy, V.; Vijayakumar, V.; Siarry, P.; Uden, L. Multi-Objective Optimization and Energy Management in Renewable Based AC/DC Microgrid R. Comput. Electr. Eng. 2018, 70, 179–198.
- [32] Zhu, Xuan, et al. « Past, Today and Future Development of Micro-Grids in China ». Renewable and Sustainable Energy Reviews, vol. 42, février 2015, p. 1453-63. Doi: 10.1016/j.rser.2014.11.032.
- [33] Wang P, Geol L, Liu X, Choo FH. Harmonizing AC and DC: A Hybrid AC/DC future grid solution. IEEE Power Energy Mag 2013; 11(3): 76–83 May/June.
- [34] Anastasiadis, Anestis G., et al. « Algorithms development for the energy management of a micro combined heat and power unit in an AC-DC microgrid ». AIP Conference Proceedings, vol. 2123, no 1, juillet 2019, p. 020093. aip.scitation.org (Atypon), doi: 10.1063/1.5117020.
- [35] Giorgos S. Georgiou, Paul Christodoulides, Soteris A. Kalogirou, Realtime Energy Convex Optimization, via electrical storage, in Buildings – A review, Renewable Energy (2019), doi: 10.1016/j.renene.2019.03.003
- [36] Megahed, Tamer F., et al. « Energy Management in Zero-Energy Building Using Neural Network Predictive Control ». IEEE Internet of Things Journal, vol. 6, no 3, juin 2019, p. 5336-44. DOI.org, doi: 10.1109/IJOT.2019.2900558.
- [37] Ismail, M. S., et al. « Design of an Optimized Photovoltaic and Microturbine Hybrid Power System for a Remote Small Community: Case Study of Palestine ». Energy Conversion and Management, vol. 5, novembre 2013, p. 271-81. Doi: 10.1016/j.enconman.2013.06.019.
- [38] Nasri, Sihem, et al. « Power Management Strategy for Hybrid Autonomous Power System Using Hydrogen Storage ». International Journal of Hydrogen Energy, vol. 41, no 2, janvier 2016, p. 857-65. Doi: 10.1016/j.ijhydene.2015.11.085.
- [39] Bruni, G., et al. « A Study on the Energy Management in Domestic Micro-Grids Based on Model Predictive Control Strategies ». Energy Conversion and Management, vol. 102, septembre 2015, p. 50-58. Doi: 10.1016/j.enconman.2015.01.067.

- [40] Ibrahim, Hussein, Mazen Ghandour. « Optimization of Energy Management of a Microgrid Based on Solar-Diesel-Battery Hybrid System ». MATEC Web of Conferences, édité par N. Moubayed, vol. 171, 2018, p. 01006. Doi:10.1051/mateconf/201817101006.
- [41] Pascual, Julio, et al. « Energy Management Strategy for a Renewable-Based Residential Microgrid with Generation and Demand Forecasting ». Applied Energy, vol. 158, novembre 2015, p. 12-25. Doi:10.1016/j.apenergy.2015.08.040.
- [42] Abushnaf, Jamal, Alexander Rassau. « Impact of Energy Management System on the Sizing of a Grid-Connected PV/Battery System ». The Electricity Journal, vol. 31, no 2, mars 2018, p. 58-66. Doi:10.1016/j.tej.2018.02.009.
- [43] Djenouri, Djamel, et al. « Machine Learning for Smart Building Applications: Review and Taxonomy ». ACM Computing Surveys, vol. 52, no 2, mars 2019, p. 1-36. DOI.org, doi:10.1145/3311950.
- [44] Jani, D. B., et al. « Application of Artificial Neural Network for Predicting Performance of Solid Desiccant Cooling Systems – A Review ». Renewable and Sustainable Energy Reviews, vol. 80, décembre 2017, p. 352-66. DOI.org, doi:10.1016/j.rser.2017.05.169.
- [45] Seyedzadeh, Saleh, et al. « Machine Learning for Estimation of Building Energy Consumption and Performance: A Review ». Visualization in Engineering, vol. 6, no 1, décembre 2018, p. 5. DOI.org, doi:10.1186/s40327-018-0064-7.
- [46] Ahmad, A. S., et al. « A Review on Applications of ANN and SVM for Building Electrical Energy Consumption Forecasting ». Renewable and Sustainable Energy Reviews, vol. 33, mai 2014, p. 102-09. Doi:10.1016/j.rser.2014.01.069.
- Puppe, Frank. Systematic introduction to expert systems: knowledge representations and problem-solving methods. Springer-Verlag, 1993.
- [47] Behrooz, Farinaz, et al. « Review of Control Techniques for HVAC Systems—Nonlinearity Approaches Based on Fuzzy Cognitive Maps ». Energies, vol. 11, no 3, février 2018, p. 495. DOI.org, doi:10.3390/en11030495.
- [48] Hu, S. David. Expert Systems for Software Engineers and Managers. Springer US, 1988. Doi:10.1007/978-1-4613-1065-5.
- [49] Puppe, Frank. Systematic introduction to expert systems: knowledge representations and problem-solving methods. Springer-Verlag, 1993.
- [50] Faia, Ricardo, et al. « Case-based reasoning using expert systems to determine electricity reduction in residential buildings ». 2018 IEEE Power & Energy Society General Meeting (PESGM), IEEE, 2018, p. 1-5. DOI.org, doi:10.1109/PESGM.2018.8585963.
- [51] Behrooz, Farinaz, et al. « Review of Control Techniques for HVAC Systems—Nonlinearity Approaches Based on Fuzzy Cognitive Maps ». Energies, vol. 11, no 3, février 2018, p. 495. DOI.org, doi:10.3390/en11030495.