

Enhancing Power Quality in Electrical Distribution Systems: A Comprehensive Review of Mitigation Techniques and Devices

¹Shekhar and ²Pramod Kumar Rathore,

¹M. Tech Scholar, RKDF College of Engineering Bhopal (MP), India

²Assistant Professor, RKDF College of Engineering Bhopal (MP), India

Abstract— Power electronic devices form a major part in today's industrial and household applications. However, the power quality of these devices is highly degraded due to lot of reasons including voltage fluctuation and flicker, harmonics, transients, voltage imbalance, and many more. These voltage disturbances lead to maximum failures in electrical distribution systems. In this review paper, various techniques including both network reconfiguring and compensating type devices are discussed to ameliorate the power quality in the distribution systems. Various power quality issues and their characteristics have been depicted. Some of the techniques discussed to improve the power quality in distribution systems which include filters, unified power quality conditioner (UPQC), dynamic voltage restorer (DVR), and distribution static synchronous compensator (D-STATCOM). The design parameters and implementation of these techniques in electrical machines are also discussed.

Index Term— CPD; D-STATCOM; DVR; UPQC; APFC Filters; Power Quality Improvement

I. INTRODUCTION

In today's world, the major problem faced in electricity usage is concomitant to the power quality issues. The degradation of electric power quality boosted awareness among users. Generally, any power system consists of three rudimentary segments, i.e. generating station, Transmission and distribution system [1]. There is an inordinate requirement for requisite power generation by the generation unit as per the demand of the customer for having a reliable power system. Also, these transmission systems are required to transmit the bulk power hindering the stability of the system or overloading it to send the signals over long distances with ease. Also, the bulk power systems are used to draw the electrical power via the distribution system must to each customer's premises [2]. The disparate classes of users have augmented the perception for deregulation of electric power quality [3]. Many attempts have been accomplished to solve the power quality problems by providing a dynamic and adaptable solution. To partly or wholly eliminating oscillating frequency component, L-C adjusted frequency to required frequency elements that are designed to have attenuation in passive filters are used extensively. Passive filters offer a higher efficiency at a very reasonable cost [4]. However, there are various stumbling blocks of these passive filters including unity impedance problem, fixed compensation, less stability

and resonance problems with both, the supply and the loads. Active power filters are used to vanquish these restrictions. Active power filter (APF) can be categorized as shunt, series and hybrid APF. Out of these, Hybrid APF is basically an amalgamation of other two APF, i.e. series and shunt APF. Application of Shunt APF is to counterpoise the current based distortions whereas the voltage based distortions are counteracted by the series APF. Completely filter the higher order harmonics, hybrid APF is being utilised. In archetypal performances, periodically problems emerges owing to the indistinguishable ratings alongside that of the load (almost 80%) [5, 6]. This entail the customer dissatisfaction as the desired power quality is unexpected. Subsequently advance power electronics devices have been made attainable to give least deformity in power supply by the means of power electronics controller devices such as custom power devices. Custom power devices are most widely employed in operation with addition to power distribution system to supply adequate power as demanded by the sensitive users [7, 8]. Voltage source inverter custom power devices are used in distribution unit as it has large dc capacitor and self-supporting dc bus voltage. Custom power devices are organized into two categories, i.e. network configuring type and compensating type. Custom power devices are used in applications of electrical machines. FACTS devices have utilization in transmission levels which are used to modulate the power flow. The high voltage side of any network is controlled by FACTS for enhancing the power flow through various power electronic devices. Corresponding to FACTS devices, a CPD comprehends the usage of higher power electronic controller at distribution level in industrial commercial and residential supply ends The FACTS controllers used in the distribution system to improve PQ is known as custom power devices (CPD). Custom power devices have their applications in distribution systems which allow them to concentrate on the quality of power flow and reliability of the system. The amenity of CPD harmonizes (well coordinated) with solitary application for which it is designed at low voltages i.e. UPS. Custom power devices illustrate that addition of more features to basic power will provide feasibility to their consumers. Distribution system is located on the end connected directly to consumer side of power system [9]. This is the reason why we need good power quality at distribution end of power system.

Initially power quality of system is improved by FACTS devices i.e. static synchronous series compensator (SSSC), static synchronous compensator (STATCOM), unified power flow controller (UPFC) and interline power flow controller (IPFC), etc. are introduced [10]. Various power quality issues are resolved with the help of custom power devices and thus improve system reliability. Based upon its structure, various custom power devices are generally classified into three broad categories: Dynamic Voltage Restorer (DVR), Distribution STATCOM (D-STATCOM) and Unified Power Quality Compensator (UPQC). Fig. 1 depicts the types of custom power devices and their categories.

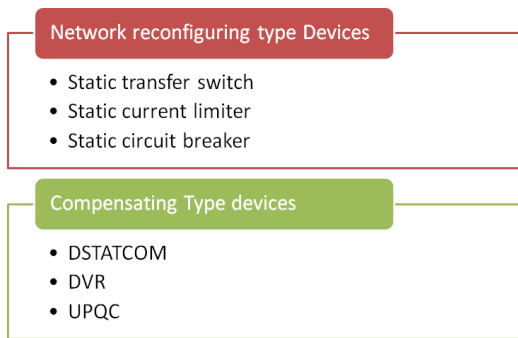

Fig.1 Classification of Custom Power Devices

These are based on voltage source converter or inverter [11]. The fusion of both D-STATCOM and DVR is regarded as UPQC. The D-STATCOM is accustomed to enhance power factor by eradicating harmonics from supply. Reactive power compensation is presuming to stable reference current. Custom power devices are characterized as active filters or power conditioners. STATCOM is situated where reactive current can be maintained at low voltages and is shunt concatenated device. The newfangled static VAR compensator is recognized as shunt connected static compensator. The VSC needs to regulate the direction of electric current through self commutation by using GTO, IGBT are used in lieu of thyristors. STATCOM are formerly recognized as static condenser [12]. Harmonics are attributable to power electronics systems. Consumer's fulfilment of need to be appropriate when distortion occurs. Issue of power quality has great influence on industrial, commercial and residential loads [13]. Different types of power quality issues arise due to electromagnetic interferences in transmission and distribution systems [14]. Electromagnetic disturbances are classified as 6 types:

- Conducted low and high frequency phenomenon
- Radiated low and high frequency phenomenon
- Electrostatic discharge phenomenon
- Nuclear electromagnetic pulse

There are temporary phenomenon's, steady state phenomenon, voltage fluctuation and flicker and power frequency variation are categorized according to different PQ applications. Temporary phenomenon is divided into transients, long

duration voltage variations, sustained interruptions, and short duration voltage variations. Steady state phenomenon is labelled as voltage imbalance (unbalance), waveform distortion[15-17].

II. TYPES OF POWER QUALITY ISSUES

Different problems occurring in electrical machines due to various power quality issues are listed below:

- Transients
- Short-Duration Voltage Variations
- Long-Duration Voltage Variations
- Voltage Imbalance
- Waveform Distortion
- Voltage Fluctuation and Flicker
- Power Frequency Variations

A. Transients

Power system transients are undesirable, fast and short duration events. Transients are defined as change in a variable which disappears in operating condition while transition from other steady state. Transients are synonymous to surge. Transients can be classified with component characteristics i.e. amplitude, rise time duration, frequency of occurrence, etc. Transients are of two types:

a) Oscillatory

An oscillatory transient represents a sudden frequency in steady state conditions and can be calculated for both voltage, and current in positive and negative polarities as it is bidirectional in nature [18]. This occurs due to various appliance switching, fast-acting overcurrent protective devices, and capacitor bank switching. Depending on frequency range high frequency transients is due to response of network, medium frequency transients is due to back to back capacitor energization, low frequency transients are due to capacitor bank energization, zero resonance and transformer energization occurs with principal frequencies which are below 300 Hz. In figure 2 oscillatory transients are given.

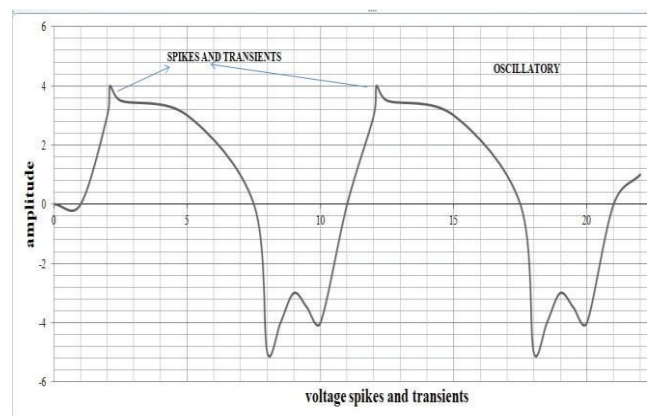

Fig.2 oscillatory transients

b) Impulsive

An impulsive transient is used to detect a sudden frequency change in the steady-state condition for both voltage and current but it is unidirectional nature in polarity. Lightning current surge is one of the most common causes of this impulsive transient. It excites natural frequency of system. It is characterized by peak value, rise time and decay time. In Fig. 3 impulsive transients are shown.

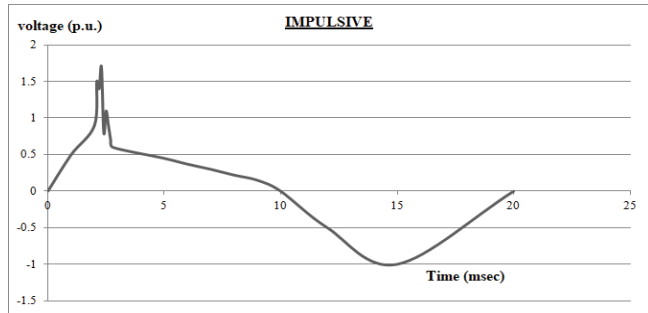

Fig.3 Impulsive transients are shown in the above figure

B. Short-Duration Voltage Variations

This short duration variations in voltage detect the voltage dips and shorter interruptions. There are basically 3 types of short duration occurrence that comprehensively includes instantaneous, momentary and temporary events. Further, each of these events is sub-divided into sag, swell and interruption. Fault conditions, loosen connections and sometimes large load energization are a cause for these conditions. Fig. 4 depicts variation voltage changes occurring in a sinusoidal voltage signal.

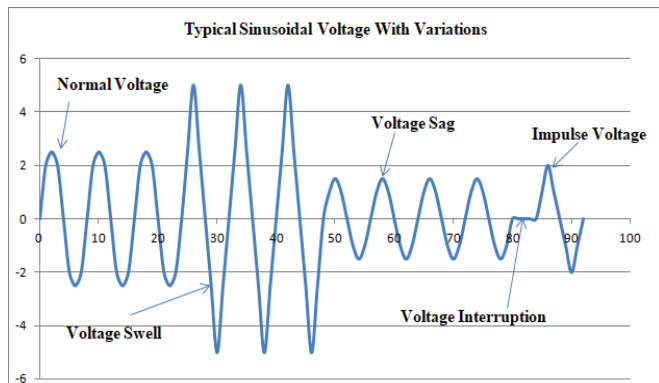

Fig. 4 Voltage sag and swell, interruption and impulse occurring in a typical sinusoidal voltage signal

These short duration voltage variations are characterized as:

a) Interruption

Whenever there is a decrease in the supply voltage or load current which decreases to less than 0.1 p.u. for a duration less than 1 minute, then interruption occurs. Some of the causes include equipment failures; blown fuse or breaker opening; and control malfunctioning. One of the major differences between the sustained interruption or long interruption is that

in former manual operation is required to restore the supply while automatic restore happens in the latter. Interruption is basically measured by its duration, which is determined by operating time of protective devices.

b) Sags(Dips)

Voltage sag occurs between starting of the fault and operation of protective device to clear the fault. IEC (international electro technical commission) defines voltage sag as dip in voltage. It depends on upon the distance of fault from the bus where sag occurs. These are mainly due to system faults. All of the shorter duration reductions in the R.M.S voltage between 0.1 and 0.9 p.u. leads to arise the sag conditions. The cycle time is usually 0.5 and a time period of 1 minute. Energizing of heavy loads is the primary cause of voltage sags when the starting of large induction motors is done. Ground faults related to single line and other reasons for transferring the load between various power sources is another reason for the occurrence of sags or dips.

c) Swells

Swell is a condition when the magnitude of the voltage increases in a range between 1.1 to 1.8. However, these swells are not as common as sags. It is characterized by its magnitude (r.m.s) and duration. These are linked with system faults such as SLG fault causes unfaulted phases. Generally, it results due to switching off a large load energizing a capacitor bank or sudden increase in voltage of various faulty phases occurring during a single line to the ground fault. Swell is also usually called a momentary overvoltage in many applications.

C. Long Duration Voltage Variations

The long duration voltage variations occur in the R.M.S. ((root mean square) voltage that is varying from a normal value for a time period longer than a minute. Load variations and other switching operations in the systems are some of the major causes of this type of voltage variations. Further, it is subdivided into three main categories, i.e. sustained interruption, undervoltage, and overvoltage.

a) Sustained Interruption

The word outage is synonymous. When the supply voltage remains zero for a time period more than one minute. The timing of a sustained interruption is approximately 3 minutes are the most severe and oldest power quality event at which voltage drops to zero and does not return automatically. Sustained duration is more than 3 minutes (that is greater than 1 minute as per IEEE). Some of the major causes of this interruption include the faults occurring without any redundancy in some parts of the power system, component or equipment breakdown due to an incorrect intervention of a protective relay or it can also be caused by any kind of scheduled interruption in a network working at a lower voltage with no redundancy. In fig. 5 sustained interruptions is shown.

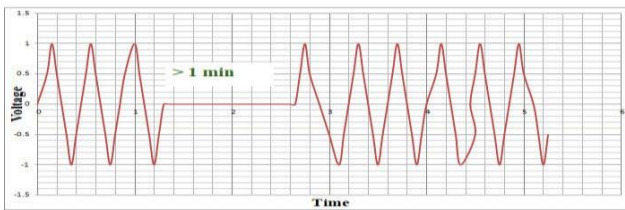

Fig.5 Sustained interruptions in long duration voltage variation

b) Undervoltage

It is a condition when the R.M.S. voltage is reduced to a value in the range of 0.8 to 0.9 p.u. for a time period more than 1 minute. Fig. 6 depicts the undervoltage disturbances.

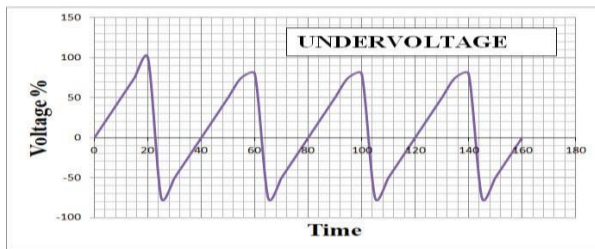

Fig.6. Undervoltage long duration voltage variation

c) Overvoltage

Overvoltage is a state where the R.M.S. voltage is increased in the range of 1.1 to 1.2 p.u. This interruption is further categorized to three types:

- (1) Overvoltage that is generated due to an insulation fault, overcompensation, tap changer transformer, ferroresonance, or other faults with alternator regulator.
- (2) Lightning overvoltage's, and
- (3) Another overvoltage occurring in the system due to rapid modifications in the network lead to Switching overvoltage. This figure 7 shows the overvoltage disturbances occurring in system.

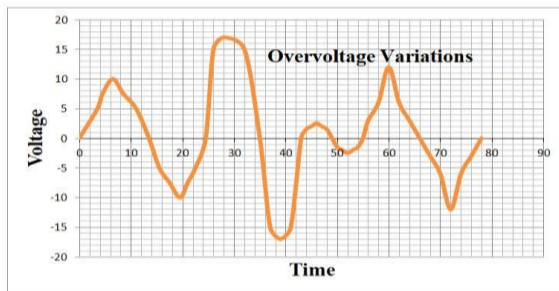

Fig.7 Overvoltage variation in long duration

D. Voltage Imbalance

It is defined as measure of unbalance ratio of the negative sequence component to positive sequence component. Voltage imbalance usually occurs in two conditions, firstly, the magnitude of the voltages of three phase system did not match or secondly, the phase difference between these voltages is not exactly 120 degrees. It can be calculated based on two techniques: first, by measuring the deviation from the average value of three phase voltages and second, by measuring the

ratio of the zero (or negative) phase component to the positive phase component. Some of the main causes of voltage imbalance in three phase system include:

- Imbalance in the single phase loading of the three-phasesystem.
- When the overhead transmission lines are not transposed.
- When one phase has its fuse blown out of the three-phase capacitorbanks.
- When severe voltage imbalance takes place leading to single phaseconditions.

E. WaveformDistortion

Waveform distortion arises due to a steady state deviation from the sine wave of frequency. In order to analyze this non - sinusoidal waveform, Fourier series is usually employed. It is further subdivided into five categories:

a) DCoffset

DC offset occurs due to the presence of a dc component, basically, a DC voltage or current in an AC system. Use of rectifiers and other electronic equipment's along with the geomagnetic devices are some of the causes of this offset voltage in the system.

b) Harmonics

Harmonics are generally sinusoidal voltages or current having the frequencies that are usually integer multiples of the fundamental frequency of power system. The main sources of these harmonics in a power system are the Industrial loads encompassing all the power electronic devices like rectifiers, high power drives, inverters, etc. or it could also include the residential loads such as switched mode power supplies for various equipment's.

c) Interharmonics

Interharmonics include the frequencies of components that are basically not integer multiples of the fundamental frequency.

d) Notching

Various line commutated thyristor circuits produce a periodic voltage disturbance that causes notching in the circuit. This occurs in the waveform of line voltage when the current commutation is taking place from one phase to another phase during its normal operation. It repeats itself after a certain period and is usually characterized by its frequency spectrum.

e) Noise

Noise is an unwanted electrical signal that occurs in the signal lines or phase conductors having a broadband spectral content lower than 200 kHz that is superimposed on the voltage or current of the power system. Filters and line conditioners can be implemented to mitigate this noise from the circuit.

F. Voltage Fluctuation And Flicker

Various systematic variations in the voltage envelope or other random voltage changes lead to the rise of voltage fluctuations in the system. The magnitude normally of these voltage envelopes usually does not exceed the specified range of 0.9 - 1.1 p.u. However, flicker is basically a continuous variation occurring rapidly that leads to voltage variations in the load current magnitude. An arc furnace can also lead to the generation of flickers.

G. Power Frequency Variations

Power frequency variation is the deviation of fundamental frequency from the nominal frequency. The deviation in power system occurs due to imbalance created by the difference in generation and demand of this frequency that ultimately leads to deviation of its power frequency.

III. VARIOUS TECHNIQUES TO IMPROVE POWER QUALITY

Harmonic currents are generated by various non linear loads that usually propagate to another location and enter back to the source by propagating in the opposite direction eventually. Further the propagation of these harmonic currents lead to the harmonic voltage propagation inside the power system devices and equipments. Various techniques have been proposed to mitigate the generation and effects of these harmonic currents and voltages in the power systems. Some of these techniques are listed below.

- Harmonic cancellation,
- High power quality equipment design
- Optimal placement and sizing of capacitor banks,
- Dedicated line or transformer,
- Derating of power system devices
- Harmonic filters (passive, active, and hybrid)
- Custom power devices such as active power line conditioners (APLCs) and unified or universal power quality conditioners (UPQCs).

Some of the most widely employed devices in the power quality improvement techniques include various types of filters including the active filters, passive filters and other hybrid filters. Other than the filters, there are some of the custom power devices that are most recently applied techniques for mitigating the power quality issues in the power systems and equipments. These custom power devices are further categorized into network reconfiguring type devices and compensating type devices. All these categories of power quality improvement techniques are discussed below in detail.

A. Filters in Power System

Harmonic filters and their implementation is an integral part of all the electrical power systems nowadays. Various significant improvements and advancements have been notified in the power electronic device technology. Due to the needs of providing a reliable and good quality source of energy, it has become essential to install filters at various stages of power electronic equipments. The problem with the

filter installation is that, it deals with only the installed bus and its harmonic voltages and currents without considering these harmonics at any other bus thereby keeping the other buses lesser in power quality. Also, a large number of harmonic filters are required due to increase in the number of non-linear loads. This leads to the new generation active filters, i.e. unified power quality conditioners (UPQCs) and active power line conditioners (APLCs). All the passive shunt filters have the basic principle of operation to provide a shunt branch having lower impedance that is generally caused by a non linear load. Filters are also used in non linear loads to compensate the harmonics via current based compensation.

a) Passive filters

Passive filters are generally utilized to prevent the significant amount of harmonic distortion locally produced from being injected in the power system of the device in industries. Passive filters are low cost fault mitigating devices used in power system where it causes significant harmonic distortion locally which is prevented from being injected into power system. They are usually placed near the non linear loads that produce harmonics in a power system. The tuning of passive filter shall be done very accurately to be lesser than that of the harmonics too be attenuated.

b) Active filters

Another feasible choice of filters to passive category is Active filters. All the places requiring dynamic compensation need an Active filter. These are used in numerous applications where either the system configuration changes or the non linear load generates continuously varying harmonics in the system. Whenever the order number of harmonics is fluctuating, in this case, active filter is usually implemented. These filters basically depend upon the active power conditioning in order to compensate various non desirable harmonics and current in the system. Active filters have a fine response for load transforming and imbalance cause by harmonics that is an advantage over passive filters. However, these active filters encompass all the other requirements for compensation in the reactive power and harmonic components. Also, these are used with three phase AC power circuits having giant penetration of non linear loads.

c) Hybrid filters

The high ratings of active filters introduce around 80% of non linear loads in various applications that serves as a major drawback. However, for both voltage and current based disturbances in power quality cannot be compensated with a single active filter. The higher cost and its quality to tolerate higher ratings have limited the use of active filters in various applications. In this case, hybrid filter has come up as a cost effective solution for providing compensation to the non linear loads. An effective and entire ability to compensate various types of non linear loads is developed by the hybrid filters. These filters basically combine the characteristics of both the active and passive filters having different types of structural topology that could be series or parallel and a combination of

both these topologies. The 5th and 7th harmonic frequencies are controlled by the passive filters whereas the higher harmonics are mitigated by the active filters. This helps in reducing the overall size and cost of the active filtering technique. Various factors are used as a base for classification of active and hybrid filters including the power rating, supply system, topology, number of active and passive elements, speed of response, compensating parameters and control approach. A more effective view is based upon the combination of both the series and shunt active filters that helps in providing compensation for both the current and voltage power quality.

B. Network reconfiguring type custom power devices

Network reconfiguring type devices are a type of custom power device that uses GTO or thyristors for the purpose of current limiting with least delay and current breaking applications. These are of following four types:

- Solid State Current Limiter
- Static Transfer Switch
- Static Breaker
- UPS

a) Solid state /Static Current Limiter(SCL)

In the static current limiting devices, various inductances are inserted in series to reduce the current level of the faults. This basically constitutes a series based connecting device. It involves a GTO with an Inductor and a snubber circuit.

b) Static Transfer Switch(STS)

Various types of sag and swell in sensitive loads are protected by using a static transfer switch (STS). Two parallel connected thyristors or GTO blocks are included in this circuit where individual block corresponds to the three phase of the power system. A bus tie position is used to connect the STS having two pair of antiparallel thyristors. This enables the fast transfer of the power supply from the faulty feeder device to an alternative feeder device within a time period of milliseconds. An uninterrupted power supply is provided to the customers at the distribution level. However the main imitation of this switch is the high conducting loss that occurs in high power application that follow in the range of 0.5 to 1 % of the load power.

c) Solid State Breaker(SSB)

Another high speed switching device is the solid state breaker that gives protection against large currents and reduces the electrical faults in the distribution systems. This device is also based upon the thyristor or GTO based technology. This SSB can also be utilized as a static transfer switch or a single switch, a hybrid switch or to reduce the faults interrupting at a lower level. An auto reclosing function is used to operate this SSB. The application of an SSB in certain power systems is based on the number of switching devices, the cost of device and other losses of the breaker for different voltage and current ratings.

d) Uninterruptible Power Supply(UPS)

Uninterruptible Power Supply (UPS) is used to outcast the problems of manufacture interference or sudden failure of the equipment as an alternative to other power supplies. Various operations are implemented in the UPS to transfer the load power from the source, like the AC to DC conversion and DC to AC conversions. In case of any interruption or voltage dip, the energy generated by the battery is used to make the load voltage to be of constant value. Due to both AC to DC and DC to AC conversions, the maintenance cost of the battery is quite high making it unsuitable for high power load.

C. Compensating Type Custom Power Devices

There are some of the custom power devices that are used for active filtering, improvement of power factor, balancing of the load and voltage regulation. Such devices are compensating type custom power devices. These compensating type devices usually consist of static shunt compensator, series and hybrid compensator. These are further categorized as D-STATCOM, DVR and UPQC respectively. These devices are explained below.

a) Unified power quality conditioners(UPQC)

Another advanced hybrid filter is called UPQC which is a feasible device that is utilized to fortify that the demands are met by the delivered power standards and specifications at the installation point. An ideal UPQC is a combination of all the three devices, i.e. current source converter, voltage source converter and a common DC link. Right shunt UPQC is the conditioner where shunt compensator is placed at the right end of the series compensator, whereas, the left shunt UPQC is the one where the shunt compensator is placed at the left end of the series compensator device. Two converters are included in the UPQC that are connected to a common DC link having energy storage capacitor banks. Various components of the UPQC are series and shunt power converters, low pass and high pass passive filters, DC capacitors, and series and shunt transformers. These UPQC compensators are utilized for the compensation of both types of distortions, i.e. three phase voltage systems and distortions occurring due to unbalanced line current having frequency components of higher order.

b) Distribution Static Compensator (D-STATCOM) Another static compensator device that is often applied to maintain the bus voltage sags is called a DSTACOM voltage source converter. It maintains the sag at the desired levels by supplying or receiving the reactive power in the distribution system. Various distribution feeders are coupled to the transformers where this DSTACOM is connected in shunt. VSC, AC filter, DC energy storage device and a coupling transformer become an integral part of a DSTACOM. With the help of energy storage systems, it can store the active power of the system. Here, the load voltages and currents are continuously observed to compensate all the disturbances in the system as the operating principle of the DSTACOM circuit. The angle between the VSC voltage and the AC power system is continuously controlled by the difference of

magnitudes of voltages to control the active power flow and also the reactive power flow.

c) Dynamic voltage restorer(DVR)

A static series compensator is usually called as Dynamic Voltage Restorer (DVR). DVR is a controlling device used in power electronics having a very high switching speed. Series voltage booster is another name for a DVR. A series connection is always considered in the DVR. Here, a voltage is injected that is dynamically controlled in both magnitude and phase by the DVR in the distribution line to improve the load voltage or make corrections to it along with a coupling transformer. This device works as an external voltage source whose amplitude, frequency and phase angle are controlled. The purpose of a DVR is to maintain the fixed load voltage by maintaining its amplitude and phase angle. An energy storage device, DC to DC boost converter, AC filter, voltage source inverter and coupling transformer are present in a DVR. Whenever, the voltage deregulation takes place, a reference voltage is generated by the DVR that is further compared with the source voltage, based on which, a synchronized voltage is injected to maintain the load voltage at a constant value.

IV. CONCLUSION

Various types of faults occurring in power distribution system and their effects on power quality has been discussed. Different devices to be used for mitigation of these problems have also been presented in this paper. Based upon different applications and effects that these devices have on the power quality, appropriate device can be selected to remove specific faults occurring in power distribution systems. In case of single bus networks, filters are found appropriate to remove the voltage fluctuations and harmonic currents. However, for multi-bus and complex network configurations, most of the types of filters are found inappropriate and custom power devices are required. Different network reconfiguring type devices are found to solve the problems of sags and swells in all the buses of a network and deals with large amounts of currents and distortions in the network. Further, load balancing and voltage regulation are more efficiently met with

the help of compensating type custom power devices including DSTATCOM and DVR.

REFERENCES

- [1] P. Anitha Rani, Sivakumar. R, "Improvement of Power Quality using DVR in Distribution Systems", IJRSET, vol. 3, Issue 1, pp. 761 – 766, 2014.
- [2] P. Bapaiah, "Power quality improvement by using DSTATCOM", IJETEE, vol. 2, Issue 4, 2013.
- [3] M. L. Crow, "Power quality enhancement using custom power devices", IEEE Power and Energy Magazine, vol.2, pp.50, 2004.
- [4] Prafull A. Desai, Vishvadeep J. Dhawale, Ranjeet M. Bandgar, "Review Paper on the Custom Power Devices for Power Quality Improvement", IJEEE, Vol. 7, Issue 7, pp. 723-733, 2014.
- [5] M.H. Haque, "Compensation of distribution system voltage sag by DVR and D-STATCOM", IEEE Power Tech., vol.1, pp. 5, 2001.
- [6] H. Mehta, V. H. Tahiliani, J. E. Sullivan, "Custom Power: an opportunity for energy conversion", International Conference on Electricity Distribution CIREC, pp. 503, 1993.
- [7] C. Sankaran, "Power quality", CRC Press LLC, New York, 2001.
- [8] J. Stones, A. Collinson, "Power quality", Power Eng. Journal, vol.15, pp.5864, 2001.
- [9] M.H.J. Bollen, "What is power quality?" Electric Power Systems Research, vol.66, pp.5-14, 2003.
- [10] S.R. Nam, J.M. Sohn, S.H. Kang, J.K. Park, "Fault Location Algorithm for Ungrounded Radial Distribution system", in Journal of Electrical Engg. Vol.89, Issue 6, pp. 503-508, 2007.
- [11] P. Heine, M. Khronen, Voltage Sag Distributions Caused by Power System Faults, in IEEE Transmission Power system, vol. 18, Issue 4, pp. 1367-1373, 2003.
- [12] M. Mangaraj, T. Penthia, A. K. Panda, "Power quality improvement by a 3-phase 4-leg supercapacitor based DSTATCOM", UPCON, IEEE Conference, vol., pp. 91-97, 2017.
- [13] D.M. Vilathgamuwa, A.A.D.R. Perera, S.S. Choi, "Voltage Sag Compensation with Energy Optimized Dynamic Voltage Restorer", IEEE Trans. on Power Del., vol. 11, Issue 3, pp. 928-936, 2003.
- [14] P. Boonchiam, N. Mithulanathan, "Understanding of Dynamic Voltage Restorers through MATLAB Simulation", Thammasat Int. J. Sc. Tech., vol. 11, Issue 3, 2006.
- [15] Francisco Jurado, Manuel Valverde "Fuzzy logic Control of a Dynamic Voltage Restorer", IEEE-ISIE, vol. 2, pp. 1047-1052, 2004.
- [16] N. G. Hingorani, "Introducing custom power", vol. 32, pp. 41-48, 1995.
- [17] A.S. Anees, "Grid integration of renewable energy sources: Challenges issues and possible solutions", Proc. IEEE 5th India International Conference on Power Electronics (IICPE), vol. 2, pp. 1-6, 6-8 Dec. 2012.
- [18] G.M. Shafiullah, A. M. T. Oo, "Analysis of harmonics with renewable energy integration into the distribution network", Smart Grid Technologies — Asia (ISGT ASIA) IEEE Innovative, vol. 1, pp. 1-6, Nov. 2015.