

A Novel Maximum Power Extraction Approach for Solar and Wind (Hybrid) Renewable Energy Systems

¹Jagdish Kumar Barde and ²Nitin Choudhary,
¹PG Student, ²Assistant Professor,
^{1,2}Kopal Institute of Science & Technology, Bhopal, India

Abstract— As we know that power derived from solar and wind system is not always constant and consistent. In india weather changes frequently so in cloudy condition there will be minimum power from PV cell while in summer it is maximum. So weather reduces the efficiency of the system. As a result, an energy efficient method is required to locate the optimal operating point to extract the maximal amount of energy under different atmospheric conditions. This paper proposed a modified perturb and observe maximum power point tracking controller for wind and solar-wind hybrid energy systems. The controller uses a modified fixed perturb and observe method to reach MPP by varying the duty cycle of each input module. Results are provided on a 200W wind system as well as a 400W solar-wind energy system with varying irradiation intensity and wind speed to highlight the merits of the work.

Keywords—MPPT; P&O Method; Wind Energy System; Solar Energy Systems; Hybrid Energy Systems

I. INTRODUCTION

Solar and wind energy are one of the most promising renewable energy resources due to their simplicity and the advancement in their field. Solar energy has the highest growth rate among renewable energy resources with its global capacity having increased from 5.1GW to 227GW from 2005 to 2015. Wind power global capacity increased from 59GW to 433GW in the same time period [1]. Solar and wind energy systems have a variety of applications. The two major areas of application for photovoltaic (PV) systems are stand-alone (water pumping, street lighting, electric vehicles and space applications) [2] and grid connected configurations (hybrid systems, power plants) [3]. Application areas for low power wind turbines also include grid connected configurations [4]-[5] as well as battery charging [6]. However, PV and wind turbine modules do not generate constant amount of power. Their output is directly affected by factors including the position of the sun, cloud cover, wind speed, and the clarity of the atmosphere. Wind turbine modules' speed power characteristics are nonlinear and change with wind speed. The same applies to the voltage-power characteristic of the PV modules which vary with irradiation and temperature. For both cases, there is only one operating point, known as the Maximum Power Point (MPP), at which the PV and wind turbine modules operate at maximum efficiency. The location of the MPP is unknown, but can be located, through the use of calculation models or search algorithms. Energy systems do not naturally operate at this condition. Therefore, a maximum power point tracking (MPPT) controller is required to locate the optimal operating point such that the maximum power can be extracted at different operating conditions. Several MPPT techniques [7] have been presented in literature for solar and wind energy systems such as first order differential, fuzzy logic [7][9], perturb and observe [7][8][10][12], and

incremental conductance [7][13]-[14]. Each method has its own advantages and disadvantages. Among these methods, the basic perturbation and observation (P&O) technique requires less system parameters and is relatively simple to implement [8][18]. Conventional MPPT techniques oscillate around the maximum power point (MPP) which leads to ripple losses. They also rely on complex mathematical functions such as a proportional-integral (PI) controller [20]-[23]. This paper proposes a MPPT controller for a wind energy as well as hybrid solar-wind energy systems. The proposed control method, which is a modified perturb and observe (P&O) method, is able to extract the maximum power from the energy while minimizing the output voltage and power ripple by varying the converters duty cycle. The controller is able to track the MPP for both solar and wind energy modules without requiring change to its code. The implemented logic design does not require complex mathematical functions and is compatible with both single and multi-input converters. The operating principle of the proposed controller is presented in this paper. The performance of the controller is verified through a 200W wind energy system as well as a 400W solar-wind energy system.

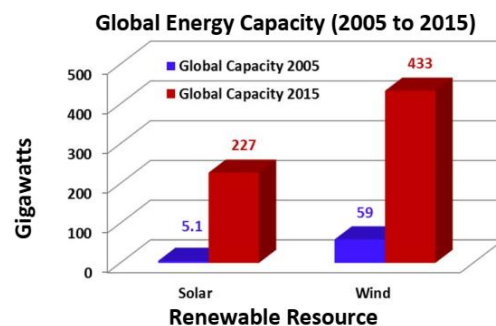

Figure 1: Global Energy Capacity of Solar and Wind Energy Systems

II. OPERATING PRINCIPLE OF PROPOSED MPPT CONTROLLER

The operating speed and torque of a wind turbine are directly related to the wind speed. At each wind speed there is a different speed-power curve. For each curve there is a single operating turbine speed at which the maximum amount of power can be obtained. Fig. 2 shows an example of two different speed-power curves for a wind turbine. In this example, when the wind speed changes from low to high (Fig. 1(a) and Fig. 1(b)) the optimal operating point shifts from 9 rad/s to 15 rad/s. However the operating point of the turbine has not changed. The turbine is still rotating at a speed of 9 rad/s. As a result a controller is required to move the operating point from its current location to the optimum location so that the maximal amount of energy can be extracted. This can be achieved by changing the operating frequency or duty cycle of the converter. In a series of iterations the controller will move the operating point of the wind turbine from 9 rad/s to 15 rad/s

as seen in Fig. 1(c). The same process is performed with MPP tracking for PV panels. For each light intensity, there is a different voltage-power curve which has an optimal operating point. As the intensity changes, the controller will shift the operating voltage of the panel to its optimal point. The controller used in this paper is a modified duty cycle based P&O controller. By varying the duty cycle of the converter's switch, the operating speed of the turbine and operating voltage of the PV panel can be changed such that the best operating point can be reached.

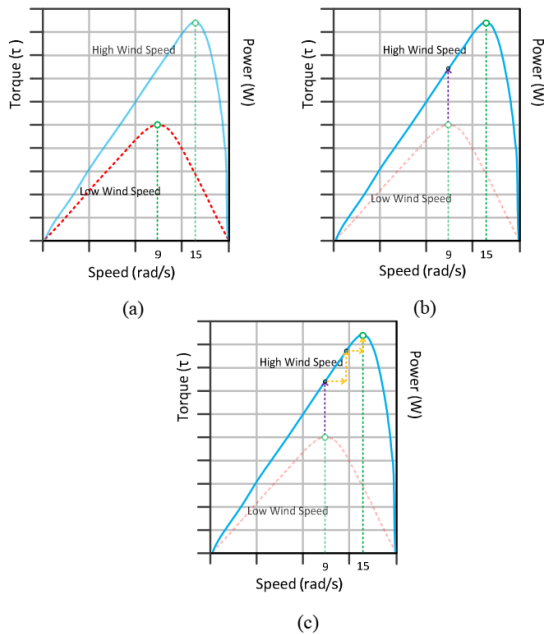

Figure 2: Maximum power point tracking using conventional P&O

The logic flow chart of the proposed MPPT algorithm is shown in Fig. 3. The controller tracks the MPP by varying the duty cycle of the converter. In each iteration, the control function is performed by first measuring the operating speed and torque of the wind turbine and then calculating the corresponding power. From here the controller calculates the change in the output power (ΔP) as given by (1), the change in the operating speed (Δv) given by (2) and the direction of duty cycle perturbation. Based on the calculated parameters, the controller will increase or decrease the operating duty cycle by a fixed amount given by (3), where k represents the current iteration and δ represents the small step change in the duty cycle

$$\Delta P = P(K) - P(K-1) \quad (1)$$

$$\Delta v = v(K) - v(K-1) \quad (2)$$

$$d(k) = d(K-1) + \delta \quad (3)$$

$$Y = f(P) = \alpha P \quad (4)$$

The frequency of the generated waveform is directly related to the time-step of the simulation. As this process continues the output power of the module will be brought to the MPP. If the input power has changed by less than a specified amount (γ) when compared to the previous cycle, the controller will maintain the existing duty cycle as given by (4), where $\alpha = 0.002$ in this design example.

From this the search for the optimum operating speed at which MPP occurs is performed and the output power can be brought to MPP. The controller uses the new duty cycle and the step size of the simulation to control the switch while maintaining a constant frequency.

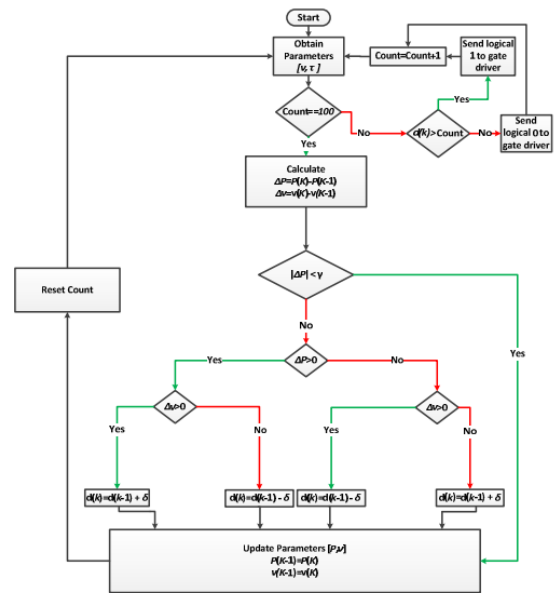

Figure 3: Control principle of the proposed MPP tracker Varying the duty cycle causes the operating speed of the turbine to change.

III. RESULTS AND ANALYSIS

Two different designs have been implemented to verify the validity of the controller. The first design consisted of an input source connected to a wind turbine along with a single phase diode-bridge rectifier and a DC-DC buck converter as shown in Fig. 5. The duty cycle of the converter was controlled to achieve MPPT. Fig. 7(a) displays the results for the wind turbine operating at wind speeds from 10m/s to 13.4m/s. When the wind speed changed the controller took approximately 7ms to bring the turbine power to the MPP while limiting the power ripple to approximately 1% of the MPP. The second design consisted of a PV panel and a wind turbine connected to a multi-input converter as shown in Fig. 4. Three scenarios, namely, changes in solar irradiation, wind speed, or the simultaneous changes in both, were tested to see if the controller could track the MPP. In all three cases, the controller was able to bring the output power of the module to the maximum. Fig. 8 displays the results for the hybrid system with the wind speed and light intensity varying from 10m/s to 13m/s and 400W/m² to 700W/m² respectively. When the value of the input sources changed the controller took approximately 7ms and 8ms to bring the output power to its maximum for wind and PV respectively. The controller shifted the operating point to its maximum for the PV panel and the wind turbine.

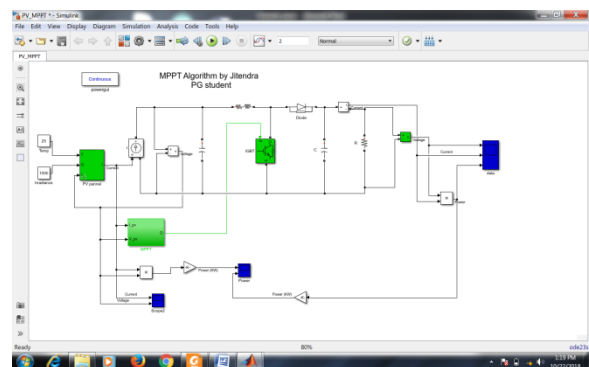

Figure 4: PV system with MPPT controller

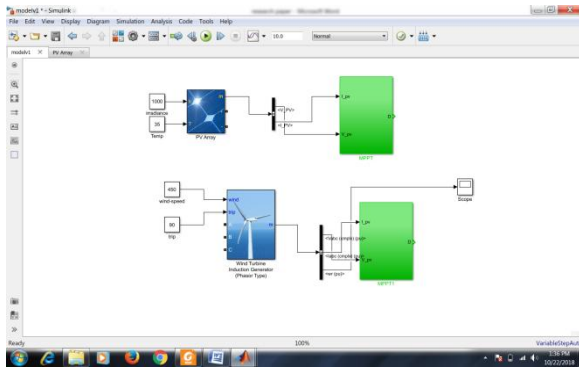

Figure 5: PV and Wind system with MPPT controller

Figure 6: output power, voltage and current

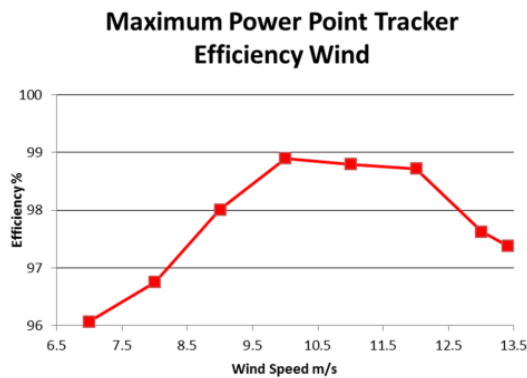

Figure 7: Maximum power point tracker efficiency with varying wind speed

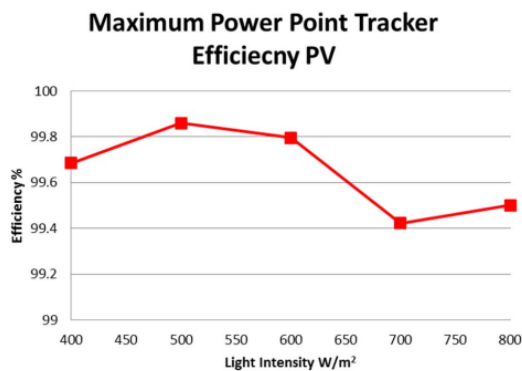

Figure 8: Maximum power point tracker efficiency with varying light intensity

Fig. 7 and 8 represent the controller efficiency for the wind energy system and the hybrid energy system respectively. From Fig. 8, it can be seen that the maximum power point tracker efficiency is above 97% for wind speeds from 10m/s to 13.4m/s with an average efficiency of approximately 98.2%. When the wind speed is below 10m/s the efficiency is lower however it is still over 90% with a total efficiency of 97.8%. In Fig. 9 the maximum power point tracker efficiency is above 99% for light intensities ranging from 400W/m² to 800W/m² with an average efficiency of approximately 99.6%. The controller's efficiency for the PV panel is high due to ripple minimization.

CONCLUSION

This paper has presented a modified perturb and observe maximum power point controller for wind energy systems. Simulation results have been provided to highlight the features of the proposed controller. The controller has shown to be able to track the MPP within 7ms for wind turbines and 8ms for PV panels while keeping the MPP oscillation to a minimum. The controller is able to maintain an average efficiency of 97.7% for the first system and 99.6% for the second system.

References

- [1] REN21 "The First decade: 2004-2014" report. <http://www.ren21.net>
- [2] J. Schaefer, "Review of photovoltaic power plant performance and economics," *IEEE Transactions on Energy Converters*. pp. 232–238, 1990.
- [3] N. Femia, D. Granozio, G. Petrone, G. Spagnuolo, and M. Vitelli, "Optimized one-cycle control in photovoltaic grid connected applications," *IEEE Transactions on Aerospace Electronic Systems*, Vol. 42, pp. 954–972, 2006.
- [4] M. Kiani, D. Torregrossa, M. Simoes, F. Peyraut and A. Miraoui, "A novel maximum peak power tracking controller for wind energy systems powered by induction generators," in *Proc. of the 2009 IEEE Electrical Power & Energy Conference (EPEC)*, Montreal, QC, pp. 1-3.
- [5] G. Gamboa, J. Elmes, C. Hamilton, J. Baker, M. Pepper and I. Batarseh, "A unity power factor, maximum power point tracking battery charger for low power wind turbines," in *Proc. of the 2010 IEEE Applied Power Electronics Conference and Exposition (APEC)*, Palm Springs, CA, pp. 143-148.
- [6] N. Mendis, K. M. Muttaqi, S. Sayeef and S. Perera, "Standalone Operation of Wind Turbine-Based Variable Speed Generators With Maximum Power Extraction Capability," *IEEE Transactions on Energy Conversion*, vol. 27, no. 4, pp. 822-834, Dec. 2012.
- [7] T. Esram and P. L. Chapman, "Comparison of Photovoltaic Array Maximum Power Point Tracking Techniques," *IEEE Transactions on Energy Conversion*, vol. 22, no. 2, June 2007, pp. 439-449.
- [8] M. Shirazi, A. H. Viki and O. Babayi, "A comparative study of maximum power extraction strategies in PMSG wind turbine system," in *Proc. of the 2009 IEEE Electrical Power & Energy Conference (EPEC)*, Montreal, QC, pp. 1-6.
- [9] Yi-Hsun Chiu, Yu-Shan Cheng, Yi-Hua Liu, Shun-Chung Wang and ZongZhen Yang, "A novel asymmetrical FLC-based MPPT technique for photovoltaic generation system," in *Proc. of the 2014 International Power Electronics Conference (IPEC)*

Hiroshima 2014 - ECCE ASIA), Hiroshima, pp. 3778-3783.

- [10] S. K. Ji, H. Y. Kim, S. S. Hong, Y. W. Kim and S. K. Han, "Nonoscillation Maximum Power Point Tracking algorithm for Photovoltaic applications," in *Proc. of the 2014 Power Electronics and ECCE Asia (ICPE & ECCE)*, Jeju, pp. 380-385.
- [11] S. Poshtkouhi and O. Trescases, "Multi-input single-inductor dc-dc converter for MPPT in parallel-connected photovoltaic applications," in *Proc. of the 2011 IEEE Applied Power Electronics Conference and Exposition (APEC)*, Fort Worth, TX, pp. 41-47.
- [12] I. Colak, E. Kabalci and G. Bal, "Parallel DC-AC conversion system based on separate solar farms with MPPT control," in *Proc. of the 2011 Power Electronics and ECCE Asia (ICPE & ECCE)*, Jeju, pp. 1469-1475.
- [13] G. Cipriani, V. D. Dio, F. Genduso, R. Miceli and D. L. Cascia, "A new modified Inc-Cond MPPT technique and its testing in a whole PV simulator under PSC," in *Proc. of the 2015 IEEE Applied Power Electronics Conference and Exposition (APEC)*, Charlotte, NC, pp. 3060- 3066.
- [14] S. Dwari, L. Arnedo, S. Oggianu and V. Blasko, "An advanced high performance maximum power point tracking technique for photovoltaic systems," in *Proc. of the 2013 IEEE Applied Power Electronics Conference and Exposition (APEC)*, Long Beach, CA, 2013, pp. 3011- 3015.
- [15] H. Patel and V. Agarwal, "Maximum Power Point Tracking Scheme for PV Systems Operating Under Partially Shaded Conditions," *IEEE Transactions on Industrial Electronics*, vol. 55, no. 4, pp. 1689-1698, April 2008.
- [16] J. H. R. Enslin, M. S. Wolf, D. B. Snyman and W. Swiegers, "Integrated photovoltaic maximum power point tracking converter," *IEEE Transactions on Industrial Electronics*, vol. 44, no. 6, pp. 769-773, Dec 1997.