

# Design of Solar Home System

Than Than Swe

Electrical Power Engineering Department, Technological University (Banmaw), Banmaw, Kachin State, Myanmar

**Abstract**—This paper is to design of solar home system for a model home. The selected Photovoltaic (PV) 300 W modules are used by combining series and parallel to generate the desired capacity. The calculation results of correct tilt angle and solar angles of the array depend on the selected location, Latitude and Longitude, and available sunshine hours. The demand of a model home requires a DC 12 V battery with a capacity of 200 Ah in order to be charged and discharged the rated power at any weather condition. The charge controllers are evaluated that can control over charging and deep discharges of system battery. For AC loads, 20 kW of pure sine wave inverter is one of the best components among various inverters for solar home system. By estimating the required battery capacity for the proposed system and the GJ12-200 battery is chosen to use in off-grid system. The charge controller with maximum charging current of 100 A, model Galaxy is selected.

**Keywords**—PV Module, Charge Controller, Inverter, Battery

## I. INTRODUCTION

Solar electrification system intends to apply for remote and rural areas in Myanmar. Everyday, the sun radiates an enormous amount of energy called solar energy. It radiates more energy in one day than the world uses in one year. This energy comes from within the sun itself. Solar energy is available in abundance in most parts of the world. PV systems convert sunlight directly to electricity. They work any time the sun is shining, but more electricity is produced when the sunlight is more intense and strikes the PV modules directly. PV modules are marvelously simple, effective, and durable. They sit in the sun and with no moving parts, can run appliances, charge batteries or make energy for the utility grid. PV produces electricity from a clean, renewable resource without noise or air pollution. This research work focuses on the extraction of electrical features using solar energy data, solar angles and off-grid electrification method.

## II. PROPOSED SYSTEM DESIGN

Very few people know how to design a solar home system. A healthy solar home system design should leave some space for the system to sustain a longer life. In designing of solar home photovoltaic system, there are two main parts to be considered: mechanical design and electrical design.

### A. Mechanical Design

The mechanical integration of PV arrays and associated equipment involves the consideration of many factors, including:

- Mounting location, orientation and shading
- Type of mounting surface
- Tilt angle of module
- Design configuration
- Hardware components for mounting system
- Thermal characteristic of modules

### B. Electrical Design

The following factors are the design procedures for the proposed site. They are

- Estimating daily load energy consumption,
- Selection of system voltage
- PV array sizing
- Inverter sizing
- Battery sizing
- Solar charge controller sizing

## III. DESIGN CALCULATION

This paper is designed for off-grid solar home system. This system concerned with the site location and solar radiation that can be received by the proposed site.

### A. Proposed Site location

The proposed site was chosen a two floors house in Se Hae Quarter, Banmaw Township, Kachin State. This building is located at North Latitude of 24.227° and East Longitude 97.266°. The main purpose of off-grid solar home system is to supply electricity for a two floors house. This building includes four bedrooms, one set of toilet and bathroom, three living rooms and one set of dining room and kitchen.

### B. Load demand

This system is designed for single phase system due to the types of loads in proposed building. Power demand and energy demand are 15285 W and 57690 Wh. System voltage is 220 V.

### C. Inverter sizing

The inverter size should be 25 to 30 percent bigger than total watts of appliances. For off-grid systems, the input rating of the inverter should be the same as PV array rating to allow for safe and efficient operation. In this design calculation of off-grid PV system with battery storage, DC/AC inverter 20kW, and 220V off-grid AC inverter shown in fig.1 is selected. So, the inverter size can be used above 20kW of greater. Table 1 shows specification of solar power inverter.



Fig 1. Single phase 20 kW 220V DC-AC inverter

### D. Charge Controller Sizing

The rating of charge controller should be 25 percent greater than short circuit current of PV array.

Charge controller sizing = 1.25 × Total short circuit current of PV array

$$\begin{aligned} &= 1.25 \times 53.64 \\ &= 67.05 \text{ A} \end{aligned}$$

The solar charge controller should be rated at 70 A and 220V or greater. Therefore, the charge controller with maximum charging current of 100A shown in fig.2 is selected. The following Table 2 shows parameters of charge controller.



Fig 2.Solar Charge Controller

Table 1: Specification of Solar Power Inverter

Output power	20kW
Output type	Single
Size	690 × 370 × 763mm
Weight	60kg
Input voltage	220V ± 20%
Output voltage	220V ± 1%
Type	DC/AC Inverters
Output frequency	50 Hz ± 0.5%
Output current	91 A
Efficiency	>85%
Color	Black
Frequency	50Hz ± 0.5%

Table2. Parameters of Charge Controller

Model Number	Galaxy
Brand Name	I-Panda
Maximum Charging Current	100 A
Application	Solar system controller
Efficiency	99.5 %
Protection	Over temperature, short circuit, etc.
Rated Voltage	220 V

**E. Battery Sizing**

The selected battery is 12 V GJ12-120 AGM lead acid battery, 2000 Ah. This battery has a length of 520 millimeters, width of 240 millimeters and height of 245 millimeters.



Fig 3. GJ12-200 V 200Ah Battery

**F. Designing PV Array**

In designing PV array, the maximum daily energy consumption must be selected. The daily energy consumption in summer is higher than other two seasons. So, the energy

consumption in summer is selected and designed for proposed system. Table 3 mentions the selected module parameters.

Table 3: Selected Module Parameters

Type of cell	Polycrystalline silicon
Power	300 W
Open Circuit Voltage	45.1 V
Maximum Power Voltage	35.2 V
Short Circuit Current	8.94 A
Maximum Power Current	8.52 A
Module Efficiency	15.3 %
Guaranteed Power Output	95%

PV array sizing is based on the energy demand (Wh) of the proposed system.

Total power demand per day for summer = 15285 W

Total energy demand per day for summer = 57690  
= 57.69 kWh

Since Banmaw Township is an area with regular rain fall and not very dusty so that derating factor for dirt is assume to be 1. Assume peak sun hour = 5.

Energy output = PV power rating × peak sun hours

Energy output per day = 1500 Wh /day

Number of total PV module = energy demand / energy output

Number of series module = system voltage / module voltage

Number of parallel = total PV modules / series modules

Array rated current = parallel module × power current of module

Array s.c current = parallel module × s.c current of module

Array rated voltage = series module × rated voltage of module

Array o.c voltage = series module × o.c voltage of module

Total module = series module × parallel module

output power = number of modules × output power of module

Sharp solar ND-F4Q300 photovoltaic module is chosen because of its efficiency is good and warranty on power output is twenty five year. The performance module has a rated power of 300 W and a module efficiency of 15.3 percent and nominal voltage of 35.2 V. The mechanical characteristic of Sharp module is made up of 72 cells connected in series, their dimension of 994 × 1971 × 46 mm and weight is 50 lbs and its frame is clear anodized aluminum alloy type. The following Table 4 shows design data sheet for PV Array.

Table 4 Design Data Sheet for PV Array

Model	Sharp Solar ND-F4Q300
Number of Parallel Modules, N <sub>p</sub>	6 Nos
Number of Series Modules, N <sub>s</sub>	7 Nos
Total Number of Modules	42 Nos
Rated array Current	51.12 A
Array Short Circuit Current	53.64 A
Array Open Circuit Voltage	315.7 V
Rated Array Voltage	246.4 V

**IV. SOLAR HOME SYSTEM**

In this system, seven modules are connected in series for one string and six numbers of string are connected in parallel.

The total numbers of module for photovoltaic array is 42 numbers. The output power of PV array supplies to the battery bank through the charge controller which prevents the batteries from overcharging and discharging. And then, the DC output from the battery bank is converted to AC by the inverter. The proposed system can get the static energy because the inverter used in the system is pure sine wave inverter. Finally, the AC output flows to the AC loads of solar home system. Fig4. illustrates the schematics diagram of the solar home system.

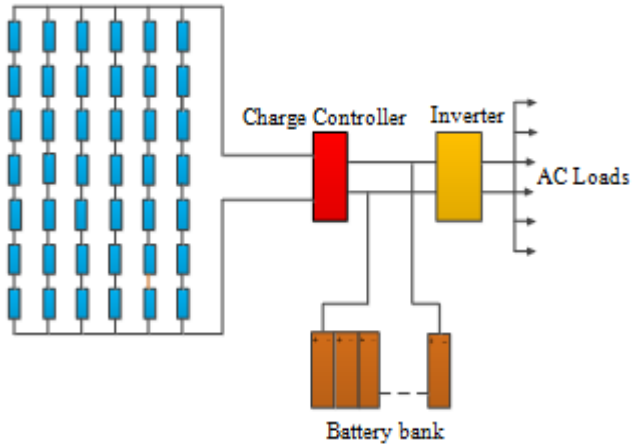

Fig 4.Schemarics diagram of solar home system

## CONCLUSION

Most of the population in developing countries live in dispersed communities in rural areas. The use of solar power system becomes attractive because of high reliability, low maintenance requirement as they don't have moving parts of the generating electricity, suited to most locations and long life expectancy for main components. Photovoltaic-power generation is reliable. The operation and maintenance costs are very low. These systems operate silently and create no atmospheric pollution. If people want lighting in the remote areas, solar is only practical way to do it because this system is easy to install.

## Acknowledgment

The author would like to express many thanks to the Pro-rector, Prof. Dr. Min Min Oo from Technological University (Banmaw).The author is deeply grateful to Associate Prof. Dr. Aye Aye from Technological University (banmaw) because of her suggestion and encouragement for this paper work.

## References

- [1] Peter Gevorkian: Solar Power in Building Design,2016
- [2] Ecofys: Planning and installation Photovoltaic systems,the German Solar Energy, UK and USA,2005
- [3] Roger Messenger and Jerry Ventre: Photovoltaic Systems engineering, London New York Washington, 2003