

Down Time Reduction in Furniture Industry

¹Karunya A, ^{2*}Rajananddine M S, ³Kumaresan K, ⁴SabariMonisha K and ⁵Saravanan S,
^{1,2,3,4}Students, ⁵Assistant Professor,

^{1,2,3,4,5}Department of Electronics and Communication Engineering, Jansons Institute of Technology, Karumathampatti,
Tamilnadu, India

Abstract: In manufacturing market, production efficiency and effectiveness are among top business priorities. Effective maintenance management focuses on increased machine's performance, control of maintenance cost, quality requirements attainment, continuous process improvement and satisfying customer needs. Production equipment becoming the central focus of interest as it is the backbone of manufacturing process and key performance indicator of productivity. Industries strives to increase the Overall Equipment Effectiveness (OEE). A manufacturer must apply an appropriate decision technique to reduce equipment downtime competently and similarly identify the machine performance. This project concerns with downtime reduction in post forming machine by alerting the operator with a message through GSM module before the heating element in the machine gets damaged and pressure gets fluctuated from the threshold value.

I. INTRODUCTION

Downtime is already a multi billion dollar problem for manufacturers. The manufacturers who are not tracking OEE(overall Equipment Effectiveness) or downtime at all, chances are they are losing money everyday. The larger the plant, more essential tracing production efficiency and downtime becomes. There is no secret that manufacturing downtime impedes to achieve production efficiency and effectiveness but there are ways to reduce downtime occurrences and in turn, improves manufacturing efficiency. The method of manual tracking is widely used, but it is rapidly shrinking with the adoption of predictive maintenance technology. The technique utilizes one or more sensors to stream machines real time data into a computerized maintenance management system (CMMS) and predicts potential failures in real time. The most significant advantage of predictive maintenance is speed. It allows operators, maintenance technicians, and production supervisors to fix downtime issues as they happen instead of weeks later. Accuracy is another benefit. The system is not only limited to informing plant managers about how much downtime occurs but also track precisely when, where and why a downtime happens. rather than waiting for your machinery to break down staying ahead of mechanical problems with preventive maintenance (PM) will significantly reduce the risk of equipment breakdown, PM involves replacing parts on a fixed schedule to ensure they don't wear out. this production strategy can help improve workflow across the production line. This paper deals with increase in the Overall Equipment Effectiveness(OEE) and efficiency of the machine. The preventive maintenance (PM) is discussed leading to the importance of reducing the downtime in furniture industry.

II. RELATED WORK

Mihir K. Shah, Vivek A. Deshpande and Ramchandra M. Patil [1] described TPM is one of most useful tool which improve effectiveness and efficiency of equipment. 5S and Kaizen are commonly used technique collaboration with TPM, which provide ground level improvements, where main focus is on

reduction of lead time and improving quality. Pardeep Gupta and Sachit Vardhan [2] recommended that augmented OEE and productivity, and reduced production cost resulted to double the sales revenue and triple the profit within a period of three years. The industry also achieved notably tangible and intangible benefits with the TPM implementation. S.F. Fam, N. Ismail, H. Yanto, D.D. Prastyo and B.P. Lau [3] study the relationship between lean manufacturing methods and overall equipment efficiency

(OEE) of the industry and focuses on the effectiveness of lean manufacturing techniques to reduce waste and to increase OEE in paper manufacturing and paper product industry. Jafri Mohd Rohania, Seyed Mojib Zahraee [4] described one of the most significant lean manufacturing techniques called Value Stream Mapping (VSM) to improve the production line of a color industry by using team formation, product selection, conceptual design, and time-frame formulation through task time calculation. S. F. Fam, S. L. Loh, H. Musa, L. M. S. Khoo and D. H. Y. Yong [5] described the sustainable development and stay competitive, Malaysian semiconductor companies are urged to implement world class maintenance techniques to improve equipment utilization and thus reduce capital expenditure. J. M. Simões and C. F. Gomes, Yasin, M. M. [6] focus on the effective utilization of maintenance resources, information systems support, and human factor management and to examine the performance measurement in the manufacturing sector.

III. METHODOLOGY

One approach to increase Overall Equipment Effectiveness (OEE) and preventive maintenance (PM) in the postforming machine of the furniture industry is to check the condition of the heating element before it gets damaged and maintain a constant pressure in the air pressure cylinder. In the heating element the temperature is being checked and when it crosses over a threshold value, the power supply to the heating elements get shut down and an alert message is sent to the operator so that it is easy for them to identify the fault or cause for the shutdown. This is applicable for air pressure as well. The postforming machine is shown in Fig 1. The block diagram for proposed system is shown in the Fig 2.



Fig 1. Post Forming Machine

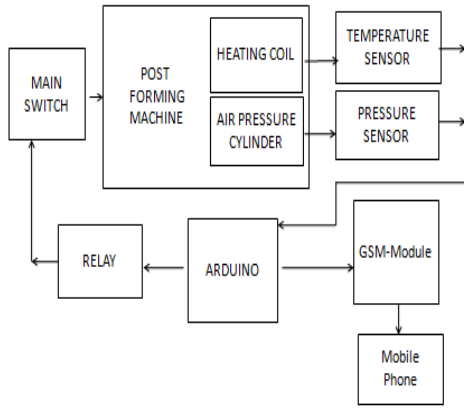

Fig 2. Block Diagram For Proposed System

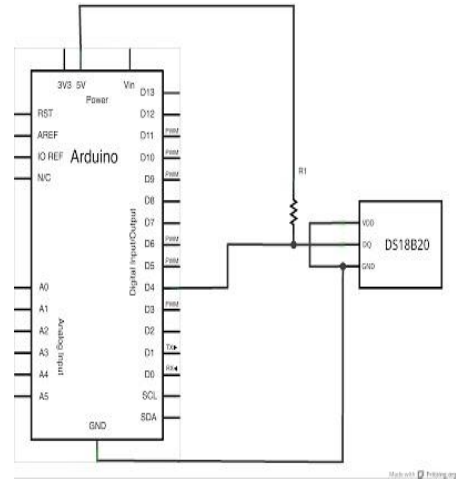

Fig 5. Pin Diagram

IV. INTERFACING THERMAL SENSOR-DB18B20 WITH ARDUINO

DS18B20 is a digital sensor to measure the temperature of the air, liquid like water and temperature of the ground .It reports the degrees in Celsius with 9 to 12 bit precision , from -55 to 125(+/-0.5).Each sensor has the unique 64 bit serial number etched into it. Power supply range is 3.0 volt to 5.5 volt. Convert temperature to 12 bit digital word in 750ms (max).Temperature accuracy from -10 deg Celsius to +85 deg Celsius. Application includes thermostatic controls, industrial system, consumer products, or any thermally sensitive system.

THERMAL SENSOR: It is a unique 1 wire interface requires only one port pin for communication. Each device has a unique 64 bit serial code stored in an on board ROM. Thermal Sensor is shown in Fig 3. Interfacing of arduino is shown in Fig 4. Pin diagram for interfacing arduino with temperature sensor is shown in Fig 5.

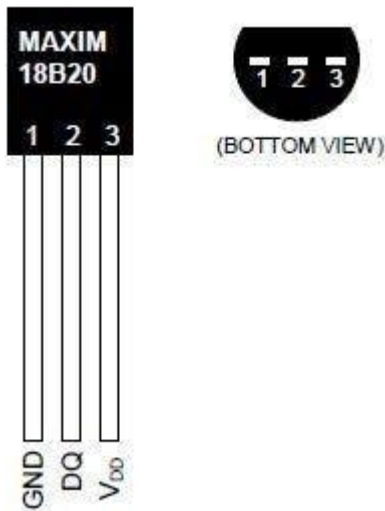

Fig 3. Thermal Sensor

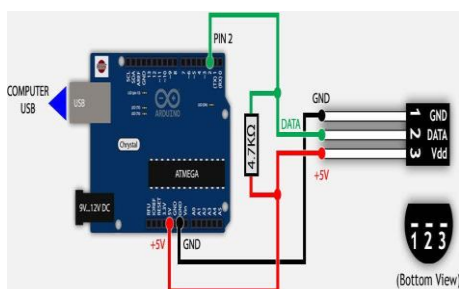

Fig 4. Interfacing Arduino

V. RESULTS AND DISCUSSIONS

Whenever the power supply is on, machine starts working and the heating coil gets heated. When the heating coil reaches its threshold value, relay gets off and the machine shut down due to over heating, which causes damage to the machine. The overall experimental setup is shown in Fig 6. The output of the experimental setup in the serial monitor is shown in Fig 7.

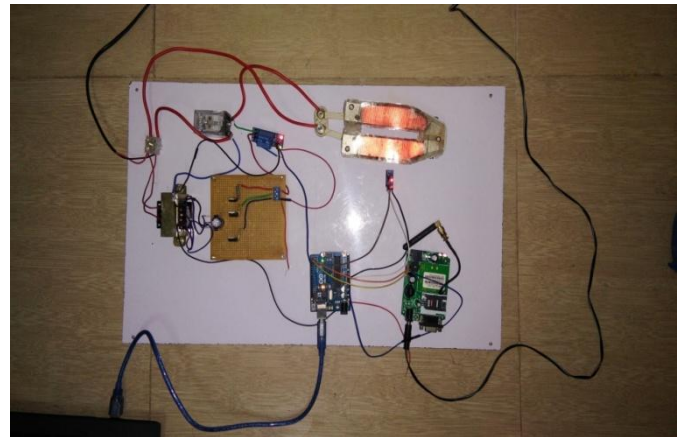

Fig 6. Experimental Setup

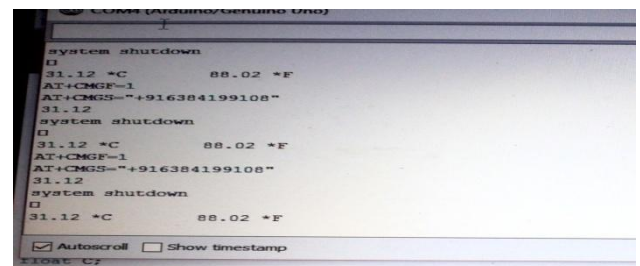

Fig 7. Serial Monitor Output

GSM module send sms to operator by altering that the heating coil reaches the threshold value before its get damage. The sms sent from the GSM to the operator's mobile is shown in the Fig 8.

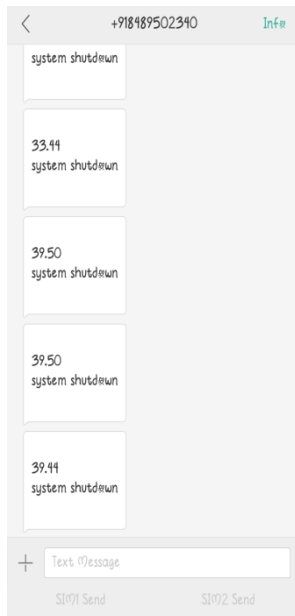

Fig 8. Output In Mobile Phone

CONCLUSION

This project reduces the downtime and increase the efficiency of the post forming machine by notifying the operator with an alert message whenever there is a fault in heating coil of the machine in the furniture industry. Thus downtime reduction of the post forming machine helps the manufacturer to increase the production and durability of the machine.

References

- [1] Mihir K. Shah ,VivekA.Deshpande and RamchandraM.Patil, “A Review on Lean Tools & Techniques: Continuous Improvement in Industry”, International Journal of Advance Industrial Engineering, Vol.3, No.4 , PP. 200-207, Dec 2015.
- [2] Pardeep Gupta and SachitVardhan, “Optimizing OEE, productivity and production cost for improving sales volume in an automobile industry through TPM:a case study”, International Journal of Production Research, Vol.54, No.10, PP.2976-2988, Feb 2016.
- [3] S.F. Fam, N. Ismail, H. Yanto, D.D. Prastyo and B.P. Lau, “Lean Manufacturing And Overall Equipment Efficiency (Oee) In Paper Manufacturing And Paper Products Industry”, Journal of Advanced Manufacturing Technology, PP.461-474, DEC 2017.
- [4] JafriMohdRohania, SeyedMojibZahraeea, “Production line analysis via value stream mapping: a lean manufacturing process of colour industry”, 2nd International Materials, Industrial, and Manufacturing Engineering Conference, MIMEC2015, PP.4-6, FEB 2015.
- [5] S. F. Fam, S. L. Loh, H. Musa, L. M. S. Khoo and D. H. Y. Yong, “Overall Equipment Efficiency (OEE) Enhancement in Manufacture of Electronic Components & Boards Industry through Total Productive Maintenance Practise”, in MATEC Web of Conference, vol. 150, no.05037, pp. 1-5, 2018.
- [6] J. M. Simões and C. F. Gomes, Yasin, M. M., “A literature review of maintenance performance measurement: A conceptual framework and directions for future research,” Journal of Quality in Maintenance Engineering, vol. 17, pp. 116-137, 2011.