

GSM Based Automated Irrigation Using Sensors

R.Subalakshmi, A.Anu Amal, S.Arthireena

PG SCHOLAR, VLSI DESIGN

M.Kumarasamy College Of Engineering, Karur, India

Abstract: The paper focuses on atomizing the irrigation system for social welfare of Indian agricultural system in order to provide adequate irrigation in the required area. The setup includes GSM technology to establish a communication link with the farmer about the soil and crop conditions automatically. It includes a 16F877 microcontroller in programming the total process. Set values are fixed for a particular crop and are programmed in the controller. Such that when the condition of the soil exceeds the set value, the GSM automatically sends a message to the farmer and the relay is turned ON.

Keywords- *Microcontroller Based Irrigation System, Humidity Sensor, Remote Operation, Sensor Based System, Controlled Irrigation.*

I. INTRODUCTION

Automated irrigation system focuses on optimizing the usage of water in agricultural land. In this project, we aim at establishing a very fast communication link with the farmer. This makes it easy for the farmers to monitor the soil and the crop conditions from very far locations. Because of its energy autonomy and its low cost, the system has the potential to be useful in water limited geographically isolated area. This system implement the automated irrigation by using PIC 16F877 and it sends the sensed value of soil temperature, moisture and humidity level to the concerned person through the gateway called GSM (Global System Monitoring). When the soil condition exceeds the set value programmed in the microcontroller, it sends the message to the farmer. GSM is the most widely used mobile technology. GSM is operated by using a subscriber identity module. When the optimum level is reached, the relay will turn on and the message is sent to the farmer through GSM and once the soil moisture is reached to the sufficient level, the motor is automatically turned OFF. The soil temperature, moisture and humidity values will be continuously displayed in the LCD display.

II. EXISTING AUTOMATED IRRIGATION

According to our survey, the projects still now existed, does not provide the easier way of communication and immediate alert and in case of any change in the moisture level in the field through SMS.

A. Related Work:

The paper presents the idea of control of irrigation, system through mobile phone using wireless communication technology. The farmer can monitor the field. "Online control of remote operated agricultural Robot using Fuzzy Controller and Virtual Instrumentation" developed a Microcontroller based fuzzy logic controller for an agricultural Robot for the purpose of ploughing, seeding and soil moisture sensing. This agricultural robot is designed with an internet based remote control system. Using LAB VIEW the position and speed of the robot is controlled. A Fuzzy logic controller and a Differential drive were designed to change and control

the steering angle and the speed of the robot. The control logic was implemented using 89C51 Microcontroller. This method of using Robot in agricultural field is not cost efficient for small land areas and can be used only for large scale agricultural lands. Another major problem is that the robot must be protected from theft which requires constant monitoring.

for , water content, and salinity and fertilizer requirement data are collected by wireless sensor network and the plant growth and overall condition of the field is monitored by the digital camera. Wireless Sensor Network (WSN) has been thus used to help the farmer to improve the yield. The Drip irrigation, which irrigates slowly to the roots of plants and onto the root zones, through a network of valves and pipe has been used.

Automated Irrigation System Using a Wireless Sensor Network and GPRS Module developed an automated irrigation system to optimize water use for agricultural crops. The system has a distributed wireless network of soil-moisture and temperature sensors placed in the root zone of the plants and gateway unit handles sensor information, triggers actuators, and transmits data to a web application. An algorithm was developed with threshold values of temperature and soil moisture that was programmed into a microcontroller-based gateway to control water quantity. The system was powered by photovoltaic panels and had a duplex communication link based on a cellular-Internet interface that allowed for data inspection and irrigation scheduling to be programmed through a web page. In this paper irrigation is a manual process and not an automatic process.

Microcontroller based Controlled Irrigation System for Plantation is developed for the agricultural plantation. The developed system is placed at the remote location and required water is provided for plantation whenever the humidity of the soil goes below the set-point value. Humidity sensor proportional amount of output with change in humidity, which is compared to the set point and, data is taken through the channel. If the set-point data is reached then the motor is turned ON. It provides water to the plant till the humidity goes above set-point value. After reaching the humidity above set-point value motor is turned OFF and scans the next channel. This provides right amount of water at right time. The software program is developed in assembly level language.

III. PROPOSED PAPER

To make the irrigation system simpler, the complexities involved in irrigation is tackled with automation system using microcontroller and GSM. The various environmental parameters such as soil temperature, soil moisture, relative humidity are monitored using the field. The GSM sends a MSG to the farmer, when these parameters exceed the set value defined in the program. The proposed system includes a sensor network 16F877 microcontroller, a relay, GSM, LCD display.

IV. BLOCK DIAGRAM

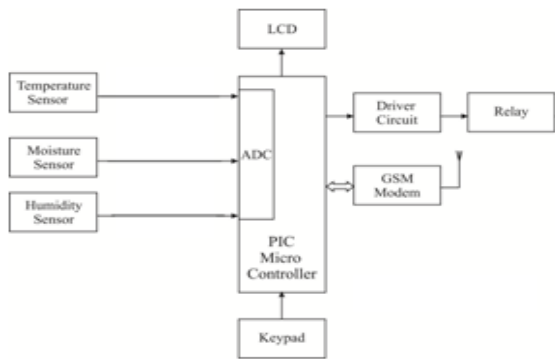

V. HARDWARE DESCRIPTION



A. Sensors & Controllers:

The above figure shows the arrangement of sensors and comparators. The system operates with 5 voltages. The land is divided into sectors and the sensors like temperature, humidity and moisture sensor are placed in the land. The set values are feeded in the microcontroller 16F877 through the program. The analog values will be converted into a digital value by ADC. Microcontroller consists of 40 pins. The sensors are connected with the PORT A of microcontroller.

B. Relay:

The 12 V solid state relay is used. When the controller scans the high data through the input channel; It sends the high signal to relay to switch ON 230 V ac supply voltage.

C. LCD (Liquid Crystal Display):

It operates at 5V. It can display 16 characters per line and there are two such lines. It has two registers namely command and data. LCD shows the current status of the soil and we can set the set values for sensors in LCD.

D. Keypad:

Matrix keypad is used. The set values can be entered through keypad. It helps the LCD to display the current status of the soil.

E. GSM:

A GSM modem is a wireless modem that works with a GSM wireless network. Computers use AT commands to control modems. Both GSM modems and dial-up modems

support a common set of standard AT commands. So we can use a GSM modem just like a dial-up modem. The main difference between them is that a dial-up modem sends and receives data through a fixed telephone line while a wireless modem sends and receives data through radio waves. GSM is one of the most vital components in our set up since all the communication between the users and centralized unit takes place through this modem. An external GSM modem is connected to a computer through a serial cable or a USB cable. Like a GSM mobile phone, a GSM modem requires a SIM card from a wireless carrier in order to operate. The current status of the soil will be send to the farmer as SMS.

VI. RESULT



CONCLUSION

The project is thus carried out using pic16f877 core with the help of GSM technologies. This project finds application in domestic agricultural field. In civilian domain, this can be used to ensure faithful irrigation of farm field, since we have the option of finding out moisture level of soil in a particular area.

References

- [1] Fang Meir, D. D. Garrote, D. T. Mansion and S. H. Human, 1990, Automated irrigation system using plant and soil sensors, ASAE Publication 04-90 American Society of Agricultural Engineers St. Joseph, Michigan, pp 533-537.
- [2] Clemens A. J. 1990, Feedback control system for surface irrigation management, ASAE Publication 04-90 American Society of Agricultural Engineers St. Joseph, Michigan, pp 555-560.
- [3] A Rajpal, S. Jain, N. Khare, Proc. Of the ICSE 2011, RG Education Society, ISBN 978-981-7931-0 pp 94-96.

- [4] S. R. Kumbhar, M. S. Gaikwad and M. D. Uplane, Multi-terminal Distributed Control System, Raman Memorial Conf., Nov. 1997, Pune. (India), pp 5.
- [5] A. K. Mukhopadhyay, and N. C. Dass, Microprocessor based PHESS meter, IEEE Trans. Ind Appl. IE. 1987, pp. 78 - 82.
- [6] H. Y. Zhong, H. P. Messinger, M. H. Rashid, A new microprocessor based direct torque control system for three-phase induction motor, IEEE Trans. Ind. Appl. 27, Mar / April., pp. 294 - 298.
- [7] S. R. Kumbhar, simulation and on-line parameter estimation of DC motor using computer, M. Phil. dissertation, Shivaji University, Kolhapur, 1998. (India).
- [8] S. Shanti Kumar, S. K. Biswas and J. Vithyathil, Microprocessor based field oriented control of a CIS-fed induction motor Drive, IEEE Trans. on Ind. Electronics, Vol. IE-33, pp. 39-43, Feb. 1986.
- [9] R. Johnson, Moments of a new ac induction motor control system, In Provc. European Power Electron.Conf., Aachen, Germany, pp. 17 - 22, 1989.
- [10] F. Williams and B. DeJagar, " Modeling and control of rotating stall and surge: An overview," ASME J. Turbo Machinery, Vol. 114, No. 2, pp 231-232, Apr. 1992
- [11] Data sheet of Humidity sensor HIH 4030 by Honeywell + Sparkfun Electronics. Proceedings of the International MultiConference of Engineers and Computer Scientists 2013 Vol II, IMECS 2013, March 13 - 15, 2013, Hong Kong ISBN: 978-988-19252-6-8 ISSN: 2078-0958 (Print); ISSN: 2078-0966 (Online)IMECS 20