

A Review on Different Maximum Power Point Tracker (MPPT) Approaches for PV Systems

¹Saurabh Choudhary and ²Dr.Monika Jain,
¹Student, ²Head of Department,
^{1,2}Oriental Institute of Science and Technology, Bhopal, India

Abstract— Nowadays solar energy has become the essential part of our system. It is a renewable source for electricity generation. But the problem is that the output power generated is highly nonlinear because of the nonlinear characteristics of semiconductor devices (diode, transistor). It also depends on irradiation intensity and the overall conditions.

Therefore, plenty of research works have been performed to optimize the performance and obtain maximum power from the PV panels. This paper provides a brief literature review on maximum power point tracker (MPPT) for these systems. For this purpose, the PV circuit structure with its mathematics model is presented. Then, recent publications on various design methodologies are reviewed.

I. INTRODUCTION

Technical growth, awareness about environment ,enhancement in demand for energy and public policy have all contributed to increasing interest in renewable sources of energy. Amongst various sources of renewable energy, PV is a popular one. Given the fact that the PV panels do not contain any moving parts, they lead to a significantly lower maintenance cost of compared to other systems. Moreover, the PV system can be easily used for stand-alone purposes [1]. However, nonlinear nature of the PV system originating from its dependency on weather conditions, such as irradiation and temperature, makes it difficult to operate on maximum power points in terms of $I - P$ and $V -P$ characteristics. As a result, many maximum power point tracker (MPPT) algorithms have been introduced by researchers to operate the system at optimum operating point [2], [3].

Generally, MPPT technique can be divided into two separate categories: direct and indirect approaches [1]. The direct approach of the MPPT algorithm is not required to have a prior knowledge about the PV characteristics. Perturb and Observe method [4], [5], incremental conductance method [6], [7], fuzzy logic (FL) method [8], [9] and neural network (NN) method [10] are considered as direct methods. The indirect approach uses the mathematical relationships of the system to maximize the power. The indirect approach

Includes open-circuit PV voltage method [11], short circuits PV current method [12].In addition to the above, another distinction is made by considering the exchange of information, i.e., offline versus online approaches. The offline or open loop MPPT approach applies the historical testing data of the system like open circuit voltage or short circuit current of the PV panel. There are numerous methods in this group such as neural network [13], [14], genetic algorithm [15–17]. The online approach considers real-time data from the system. Thus, it provides a better accuracy in results. The online approach consists of variety of algorithms such as perturbation and observation ($P&O$) [18–20], incremental conductance [21], [22], and ripple correlation control (RCC) [23]. In this literature review, we focus on the PV panel and various methods for the MPPT. The main goal is to provide recent technology achievements on the PV panels. The paper is organized as follows: Section II illustrates a model of the PV panel and provides its mathematical formulation. In Section III, a review of direct and indirect methods is provided. Then, various online and off-line methods are illustrated in Section IV. Finally, related design problems, conclusions, and future guidelines are discussed in Section V.

II. SYSTEM DESIGN

PV arrays consist of a large number of series and parallel solar cells [24]. Such a system can be modeled by a current source, a shunt diode, and series resistor. Figure 1 shows an equivalent circuit of the PV system. The single diode model can be a simple equivalent circuit to illustrate the PV cell. A current source is in parallel with a diode and it is directly proportional to the irradiation. The current of the PV cell, which is known as a Shockley diode equations.

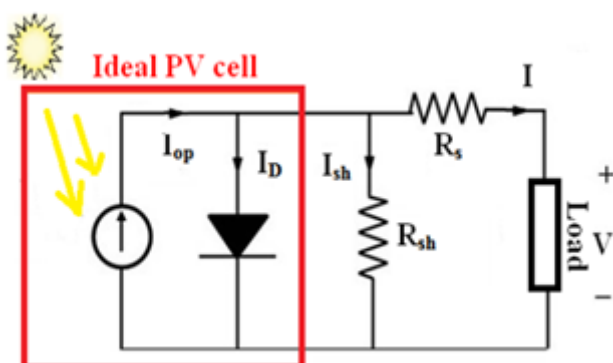

Fig. 1: An equivalent circuit of the PV.

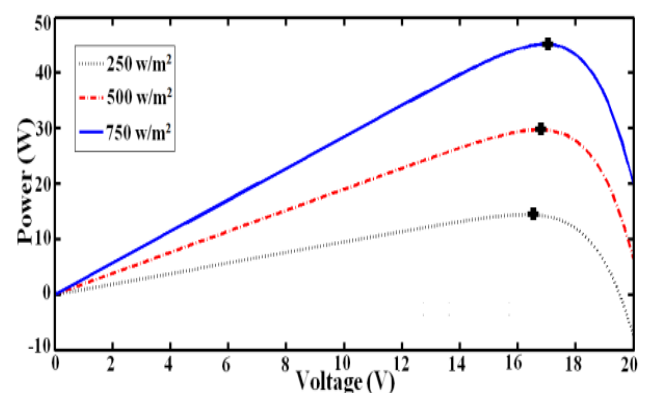

Fig. 2: Relationship between output voltage and power of the PV cell under different irradiation conditions

It is clear from Figure 2 that under a certain irradiation, there is a unique maximum point located at the knee of the curve. Furthermore, this value changes with respect to variation in the irradiation.

III. VARIOUS TECHNIQUES FOR MPPT

In this section, various direct and indirect methods are demonstrated.

A. Direct methods

Direct methods use the measurement data and computation techniques to maximize the power in the system. The most famous methods in this category are reviewed as follows:

1) Perturb and Observe (P&O) methods: The main mechanism for the perturb and observe method is simple. This method measures voltage and current of the PV panel and calculates the power. Then, it compares the result with the previous power. After this, the controller changes the duty cycle of the pulse width modulation to enhance the power in the system. The design procedure is straightforward. If the computed power is greater than the previous one, the controller holds the same direction for the duty cycle. However, if the power declines, the controller changes the direction of the duty cycle. In some research works, the perturb and observe method is also known as hill climbing (HC) algorithm [26]. It must be noted that the performance of the perturb and observe controller is high in the environment without disturbance. However, the controller provides a slow tracking which does not have a proper performance in rapidly changing conditions [27]. Therefore, the perturb and observe method often combines with other methods to improve the performance of the method in the presence of the disturbance and varying environments. A new start-stop mechanism based on the perturb and observe method is introduced in [28] to remove the steady state oscillations in the power response and maximize the power. The main aim is to improve the power performance by reducing the perturbation magnitude. However, this method reduces the speed of the system in fast irradiation conditions. Therefore, a tradeoff is made between the speed and steady state oscillation in the system. The proposed method is evaluated in a subMICs-based PV system and the experimental test scenarios show the performance of the system. An integrated method using the perturb and observe method and fuzzy logic technique is developed in [29] to operate at maximum power output in the presence of variation in solar radiation. The proposed method shows a high performance under varying irradiation conditions. A modified perturb and observe algorithm is presented in [30] to solve the problem of local maximum for the MPPT. The suggested method adds a checking algorithm to the conventional perturb and observe method to monitor all existing maximum powers and then decide how to change the controller to achieve a higher power in the system. The proposed method is validated in two environments consisting of constant and varying irradiation conditions.

2) Incremental conductance (IC) method: The Incremental conductance method is developed to address the drawback of the perturb and observe method. The method reduces the tracking time and enhances the power in varying environments [31]. The IC method considers the relationship between current and voltage ($-VI$ or $-dVI$) to adjust the controller and achieve the maximum power [31]. However, a fixed step mechanism is considered to modify the controller which may take relatively long time to reach the maximum power. Therefore, the performance is still slow in varying conditions.

A new IC method is proposed in [32] for nonlinear load. The proposed IC method considers a combination of the conductance and the rate of the conductance to deal with nonlinearity of the load. The suggested method can easily deal

with the voltage ripple and provide the MPPT. Simulation results show that the suggested method enhances the maximum power in the PV panel. In [33], An IC method using a PI controller is developed for optimizing power in the PV panel. The method uses a converter with a V-shaped impedance component to generate a higher voltage in comparison with other conventional converters. For test study, three cases including various temperatures, light intensity changes, and load uncertainty are considered. The test results indicate a proper response of the PV panel in all cases.

3) Fuzzy logic (FL) methods: Fuzzy logic is an intelligent method which can describe a system with linguistic rules using membership functions [34]. The fuzzy logic can be considered in the PV panels to model uncertainty and nonlinearity in the system and formulate the MPPT problem.

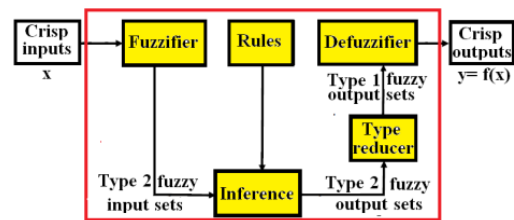

Fig. 3: Type 2 fuzzy inference system structure

A combination of fuzzy logic technique and the perturb and observe method is designed to improve the maximum power in PV panel in [35]. The proposed method utilizes power variation and voltage variation as input to the fuzzy system instead of using error and its variation which enhance the performance of the method. Then, an implementation is performed using the dsPIC digital signal controller (model: dsPIC33FJ16GS502). The experimental test results validate the effectiveness of the method. Furthermore, the fuzzy logic based controller provides a faster tracking in comparison with conventional fixed step perturb and observe method. A fuzzy logic controller via incremental conductance method is introduced in [36] to optimize the power point tracking in PV panel. The main purpose is to build some fuzzy rules based on conductance formula to achieve the maximum power for the PV panel in varying irradiation and temperature conditions. The simulation results show the capability of the proposed system in various weather conditions. A type 2 fuzzy controller is considered in [37] to achieve the MPPT in a solar cell. Simulation result shows a fast response under changes in the atmospheric conditions. Fuzzy logic type 2 controller (FLC) is designed based on fuzzy logic theory. Figure 5 illustrates type 2 fuzzy inference system structure. The type 2 fuzzy system includes fuzzifier, rule base, defuzzifier, inference engine and type reducer. This structure is similar to type 1 fuzzy inference system. The only difference is the type reducer which is added to the type 2 fuzzy system. It means the method can be formulated in the same way that a type 1 fuzzy system is developed. Due to this fact, this method is also known as interval type 2 fuzzy logic controller (IT2FLC) [38]. The appropriate modeling of uncertainty helps the type 2 fuzzy system achieve a higher accuracy.

4) Artificial Neural network (ANN) methods: Artificial neural networks are intelligent methods which can model a system with available input-output data without knowing about the physics of the system. Therefore, the neural networks are known as a block box system [39]. The ANNs are considered to model highly nonlinear systems and reach more accuracy in estimations. An Intelligent technique using feed-forward and

Elman neural networks is presented in [40] to forecast the power of the PV panel. Two-year data from the PV panel is used to train and test the proposed method. The structure of the networks must be selected with respect to the nature of the data. The simulation results show that both of the networks have a proper performance. An adaptive Neuro Fuzzy inference system (ANFIS) is presented in [41] for the high performance tracking in PV panel. The proposed method combines the learning capability of the ANN and FL to improve the accuracy of the system. Therefore, the suggested method is suitable to handle a nonlinear load or varying conditions. Several simulation tests show a higher accuracy of the ANFIS method in comparison with the fuzzy logic.

IV. RELATED DESIGN PROBLEMS, CONCLUSIONS AND FUTURE GUIDELINES

This paper reviewed the most recent control methods for maximizing power in PV and wind panels. The basic concepts of the methods with their advantages and drawbacks were illustrated. In the following, some conclusions and future guidelines are provided:

1-The perturb and observe method and incremental conductance method can be easily implemented and have an acceptable performance in stable environments. However, their performances are low in varying conditions. These methods can be combined with other methods like fuzzy logic, genetic algorithm and etc to be suitable for rapidly changing environments.

2- Recently, advance control technologies such as sliding mode, feedback control have been noticed for the PV system due to their accurate results. Therefore, adaptive advance control methods are highly appreciated to deal with varying conditions such as changes in temperature or irradiation.

References

- [1] V. Salas, E. Olias, A. Barrado, and A. Lazaro, "Review of the maximum power point tracking algorithms for stand-alone photovoltaic systems," *Solar energy materials and solar cells*, vol. 90, no. 11, pp.1555–578, 2006.
- [2] A. Manmohan, A. Prasad, R. Dharavath, S. P. Karthikeyan, and I. J. Raglend, "Up and down conversion of photons with modified perturb and observe mppt technique for efficient solar energy generation," *Energy Procedia*, vol. 117, pp. 786–793, 2017.
- [3] M. Abdulkadir and A. H. M. Yatim, "Hybrid maximum power point tracking technique based on pso and incremental conductance," in *Energy Conversion (CENCON), 2014 IEEE Conference on*. IEEE, 2014, pp. 271–276.
- [4] S. Hajighorbani, M. M. Radzi, M. Ab Kadir, and S. Shafie, "Novel hybrid maximum power point tracking algorithm for pv systems under partially shaded conditions," in *Control Conference (ASCC), 2015 10th Asian*. IEEE, 2015, pp. 1–6.
- [5] Q. A. Sias and I. Robandi, "Recurrence perturb and observe algorithm for mppt optimization under shaded condition," in *Intelligent Technology and Its Applications (ISITIA), 2016 International Seminar on*. IEEE, 2016, pp. 533–538.
- [6] S. Twaha, J. Zhu, Y. Yan, B. Li, and K. Huang, "Performance analysis of thermoelectric generator using dc-dc converter with incremental conductance based maximum power point tracking," *Energy for Sustainable Development*, vol. 37, pp. 86–98, 2017.
- [7] A. Loukriz, M. Haddadi, and S. Messalti, "Simulation and experimental design of a new advanced variable step size incremental conductance mppt algorithm for pv systems," *ISA transactions*, vol. 62, pp. 30–38, 2016.
- [8] A. Jouda, F. Elyes, A. Rabhi, and M. Abdelkader, "Optimization of scaling factors of fuzzy–mppt controller for stand-alone photovoltaic system by particle swarm optimization," *Energy Procedia*, vol. 111, pp. 954–963, 2017.
- [9] L. Matindife and Z. Wang, "Fuzzy logic algorithms based measurement and control system for intermixed biogas and photovoltaic systems," *Procedia Manufacturing*, vol. 7, pp. 339–344, 2017.
- [10] H. Kato and K. Yamauchi, "Quick mppt microconverter using a limited general regression neural network with adaptive forgetting," in *Sustainable Energy Engineering and Application (ICSEEA), 2015 International Conference on*. IEEE, 2015, pp. 42–48.
- [11] A. Ramasamy and N. S. Vanitha, "Maximum power tracking for pv generating system using novel optimized fractional order open circuit voltage-foinc method," in *Computer Communication and Informatics (ICCCI), 2014 International Conference on*. IEEE, 2014, pp. 1–6.
- [12] H. A. Sher, A. F. Murtaza, A. Noman, K. E. Addoweesh, K. AlHaddad, and M. Chiaberge, "A new sensorless hybrid mppt algorithm based on fractional short-circuit current measurement and p&o mppt," *IEEE Transactions on Sustainable Energy*, vol. 6, no. 4, pp. 1426– 1434, 2015.
- [13] A. Anzalchi and A. Sarwat, "Artificial neural network based duty cycle estimation for maximum power point tracking in photovoltaic systems," in *SoutheastCon 2015*. IEEE, 2015, pp. 1–5.
- [14] V. V. Ramana and D. Jena, "Maximum power point tracking of pv array under non-uniform irradiance using artificial neural network," in *Signal Processing, Informatics, Communication and Energy Systems (SPICES), 2015 IEEE International Conference on*. IEEE, 2015, pp. 1–5.
- [15] A. Al-Gizi, A. Craciunescu, and S. Al-hlaihawi, "Improving the performance of pv system using genetically-tuned flc based mppt," in *Optimization of Electrical and Electronic Equipment (OPTIM) & 2017 Intl Aegean Conference on Electrical Machines and Power Electronics (ACEMP), 2017 International Conference on*. IEEE, 2017, pp. 642– 647.
- [16] A. Badis, M. N. Mansouri, and A. Sakly, "Pso and ga-based maximum power point tracking for partially shaded photovoltaic systems," in *Renewable Energy Congress (IREC), 2016 7th International*. IEEE, 2016, pp. 1–6.
- [17] H. W. Salih, S. Wang, and B. S. Farhan, "A novel ga-pi optimized controller for mppt based pv in a hybrid pv-diesel power system," in *Electric Utility Deregulation and Restructuring and Power Technologies (DRPT), 2015 5th International Conference on*. IEEE, 2015, pp. 1288–1293.
- [18] S. Choudhury and P. K. Rout, "Comparative study of m-fis flc and modified p&o mppt techniques under partial shading and variable load conditions," in *India*

- Conference (INDICON), 2015 Annual IEEE. IEEE, 2015, pp. 1–6.
- [19] M. A. A. M. Zainuri, M. A. M. Radzi, A. C. Soh, and N. A. Rahim, "Development of adaptive perturb and observe-fuzzy control maximum power point tracking for photovoltaic boost dc-dc converter," *IET Renewable Power Generation*, vol. 8, no. 2, pp. 183–194, 2013.
- [20] S. K. Kollimalla and M. K. Mishra, "A novel adaptive p&o mppt algorithm considering sudden changes in the irradiance," *IEEE Transactions on Energy Conversion*, vol. 29, no. 3, pp. 602–610, 2014.
- [21] D. C. Huynh and M. W. Dunnigan, "Development and comparison of an improved incremental conductance algorithm for tracking the mpp of a solar pv panel," *IEEE Transactions on Sustainable Energy*, vol. 7, no. 4, pp. 1421–1429, 2016.
- [22] N. Tariba, A. Haddou, H. El Omari, and H. El Omari, "Design and implementation an adaptive control for mppt systems using model reference adaptive controller," in *Renewable and Sustainable Energy Conference (IRSEC), 2016 International*. IEEE, 2016, pp. 165–172.
- [23] M. Rafiei, M. Abdolmaleki, and A. H. Mehrabi, "A new method of maximum power point tracking (mppt) of photovoltaic (pv) cells using impedance adaption by ripple correlation control (rcc)," in *Electrical Power Distribution Networks (EPDC), 2012 Proceedings of 17th Conference on*. IEEE, 2012, pp. 1–8.
- [24] G. Walker *et al.*, "Evaluating mppt converter topologies using a matlab pv model," *Journal of Electrical & Electronics Engineering, Australia*, vol. 21, no. 1, p. 49, 2001.
- [25] M. Veerachary, T. Senjyu, and K. Uezato, "Voltage-based maximum power point tracking control of pv system," *IEEE Transactions on aerospace and electronic systems*, vol. 38, no. 1, pp. 262–270, 2002.
- [26] A. Jusoh, T. Sutikno, T. K. Guan, and S. Mekhilef, "A review on favourable maximum power point tracking systems in solar energy application," *TELKOMNIKA (Telecommunication Computing Electronics and Control)*, vol. 12, no. 1, pp. 6–22, 2014.
- [27] D. Sera, R. Teodorescu, J. Hantschel, and M. Knoll, "Optimized maximum power point tracker for fast-changing environmental conditions," *IEEE Transactions on Industrial Electronics*, vol. 55, no. 7, pp. 2629–2637, 2008.
- [28] O. Khan and W. Xiao, "Integration of start-stop mechanism to improve maximum power point tracking performance in steady state," *IEEE Transactions on Industrial Electronics*, vol. 63, no. 10, pp. 6126–6135, 2016.
- [29] G. J. G. Jothi and N. Geetha, "An enhanced mppt technique for high gain dc-dc converter for photovoltaic applications," in *Circuit, Power and Computing Technologies (ICCPCT), 2016 International Conference on*. IEEE, 2016, pp. 1–9.
- [30] R. Alik and A. Jusoh, "Modified perturb and observe (p&o) with checking algorithm under various solar irradiation," *Solar Energy*, vol. 148, pp. 128–139, 2017.
- [31] R. I. Putri, S. Wibowo, and M. Rifai, "Maximum power point tracking for photovoltaic using incremental conductance method," *Energy Procedia*, vol. 68, pp. 22–30, 2015.
- [32] P. Sivakumar, A. A. Kader, Y. Kaliavaradhan, and M. Arutchelvi, "Analysis and enhancement of pv efficiency with incremental conductance mppt technique under non-linear loading conditions," *Renewable Energy*, vol. 81, pp. 543–550, 2015.
- [33] S. Ahmadzadeh and G. A. Markadeh, "Incremental conductance based mppt using a high step-up y-source dc-dc converter," in *Power Electronics, Drive Systems & Technologies Conference (PEDSTC), 2017 8th*. IEEE, 2017, pp. 543–548.
- [34] K. Salahshoor, M. S. Khoshro, and M. Kordestani, "Fault detection and diagnosis of an industrial steam turbine using a distributed configuration of adaptive neuro-fuzzy inference systems," *Simulation Modelling Practice and Theory*, vol. 19, no. 5, pp. 1280–1293, 2011.