

# A Review on Integration of Renewable Energy Sources to the Power System (Power Electronic Transformer)

<sup>1</sup>Ajay Kumar and <sup>2</sup>Dr. A. K. Jhala,  
<sup>1</sup>Student, <sup>2</sup>Associate Professor,

<sup>1,2</sup>RKDF college of Engineering, Bhopal, Madhya Pradesh, India

**Abstract**—This paper discuss about the influence and problems caused by integration of renewable energy sources to the power system. Paper analyzes the problems of undesirable power flows that results from difficult predictability of production from these power plants. These impacts were modeled by means of program MODES on standardized power system of IEEE 39 bus System. The difference between sunny and cloudy days is compared in graphs and there is calculated that difference in percentage. Variability of wind affecting the wind power plants is also plotted in graphs. Overloading the power lines and transformers cause their outage and the imbalance between production and consumption, what shows the output of simulation.

**Keywords**— Frequency Regulation; Renewable Energy Sources; Power System; MODES;

## I. INTRODUCTION

Continuous development in the field of power electric engineering has the significant impacts on the operation conditions of the power system. Transmission system operators are increasingly facing to the critical situations, where the capacity of transmission lines is deplete. The maintenance of power grid is more difficult than during normal operation conditions. Due to a synchronous operation of the power system, there is the same security threat as well as the need to take emergency measures to prevent widespread failures in the power system. Transmission systems in Europe and especially in the southern and western parts are closely linked together. The development of systems is motivated by adapting the new trends in the electricity market and ensuring transmission of large amounts of intermittent energy from wind and also partly from the sun. The biggest problems in terms of perspective interconnected power systems are transit flows. These flows are mostly caused by the intermittent character of wind and solar energy, which unpredictably changing the entire structure of electricity generation [1][3]. The influence of renewable causes problems with the regulation of the power system, frequent overloading of transmission lines, gives a threat of disintegration of the power system. Due to the rapid expansion of renewable installed in the system requires maintenance of the balance between production and consumption a faster response to possible fluctuations. In the past, when we didn't have renewable connected to the system, we considered the only load in the system as an unknown, which has to be in some degree predictable. Nowadays the part of electricity production we consider as an unknown, which is also be in some degree unpredictable [1][5]. To ensure the stable operation of the power system the TSO regulate power on the sources providing ancillary services according to instantaneous consumption of the system, which is partially predictable, but enter to the control systems as unknown. Rapid development of renewable energy sources, especially photovoltaic power plants in the power system caused the increase in the

proportion of installed capacity, because the entire capacity must be repurchased and delivered to the system as well. The problem that was established by increasing the proportion of RES, represents a variable supply of electricity in comparison to conventional energy sources. The energy supplied from photovoltaic power plants is partly predictable by statistics from previous years for the same period of time or by weather forecasting. With the influence of climate variability is the performance of the photovoltaic power plants significantly changing and it causes disruptions and power balances in the electricity production. This phenomenon negatively affects the possibilities of system control and thus increases the requirements on ancillary reserves, which are held in reserve on conventional energy sources [2]

## II. CHARACTERISTICS OF MODELED RENEWABLE ENERGY RESOURCES

The energy from sun and the resources coming from this source as wind power plants, water and biomass can be used for producing electric power that is very necessarily for human being. Sun in the biggest and nearly unfailing source of energy for the Earth and is one of the sources on which can human totally rely. As the European commission said that we have to reduce CO<sub>2</sub>, we can use energy from sun to do it, but right now it is not possible. Photovoltaic power plants have the biggest proportion in energy mix from renewable, what is caused by grants for producing energy from these sources. Wind energy also belongs to important RES. Energy producing from these sources is affected especially by intensity and variability of wind speed. The biggest problems with unscheduled power flows between inter-connected areas are caused by them[1][4].

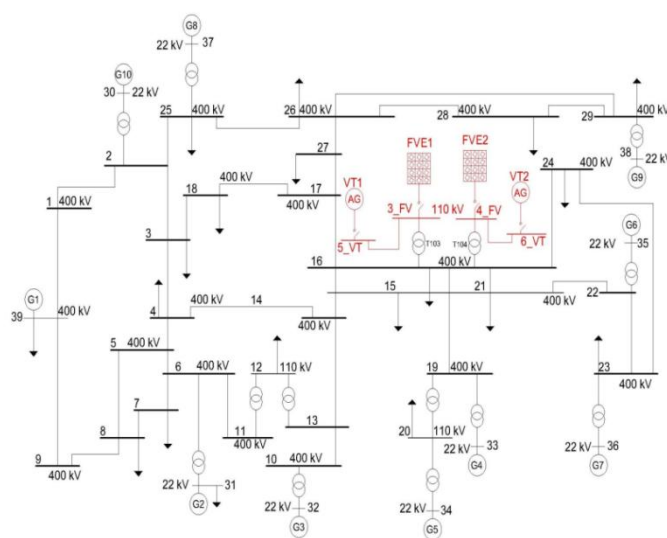

Fig. 1: The initial scheme of IEEE39 Bus System with implemented renewable energy sources (wind generators and photovoltaic invertors).

### III. THE MODEL OF INTERCONNECTED POWER SYSTEMS IEEE39 BUS SYSTEMS

This model of the power system has been implemented to the network simulator MODES as part of my research. Power system is divided into two areas and three voltage levels where are located a 10 conventional sources of electrical power. That sources represents the centralized model of generation:

- The voltage level of 400 kV - characterizes the transmission system that is under control of transmission system operator.
- The voltage level of 110 kV - is used to connect the field of centralized renewables that are under control of distribution system operator.
- The voltage level of 22 kV is used to connect other generators operating in the system and is under control of distribution system operator too [6].

Transformers T103 and T104 are an extension of the original system and are used to connect the area with installed renewable energy sources. To the transformer T103 resulting terminal from solar power plants FVE1 and wind power plants VT1. To the transformer T104 resulting terminal from solar power plants FVE2 and wind power VT2. For modeling the influence of renewable energy sources we consider that in a transformer T103 terminates a source of solar with variable radiation of intensity and also there is a variable effect of wind strength on the installed wind farm. In the area with transformer T104 is a model of solar source with clear day and low passing of clouds and moderate, not gusts wind on active wind power plant VT2. There are two identical photovoltaic power plant farms FVE1 and FVE2. Both of them are characterizes by many small power plants inside that generate to one of nodes. Due to this fact the power plant is connected to the voltage level of 110 kV. Proportion of installed PV in the power system is 4,66% from the total installed active power.

The installed capacity of wind power plants VT1 and VT2 is also identical (160 MW) and considering that this in a wind park with lots of small wind turbines operating to one node. The proportion of wind power plants in the system constitutes 2,12 % from the total installed active power. The overall proportion of renewables in this power system consists of 6,75% [1][2][6].

### IV. ANALYSIS THE INFLUENCE FROM THE RENEWABLE

Modelling the influence of renewables to the system we have performed by use of power simulator MODES. This simulator is mainly used for the analysis of transient stability in the power systems. Analysis of impacts was performed in the time range of 12 am to 1pm throughout the day. The sampling frequency was chosen one second, what gives us 86400 samples of generation from PV and from VT during the day. We choose this interval due to greater clarity of simulation outcomes and as we know the influence of PV is the biggest during the midday, when the sun is on maximum horizon [2].

#### A. Comparison of photovoltaic power plants

At the beginning of this analysis there is a comparison between the two different regions, with installed renewable sources.

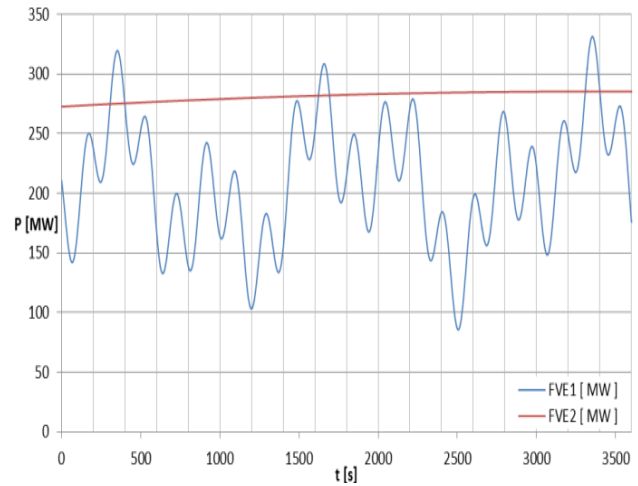

Fig. 2. Comparison of generation from PV during cloudy (FVE1) and sunny days (FVE2).

On Fig. 2 is the compared supply of active power from photovoltaic power plants. There is an output course of active power from power plants gathered in FVE2, where was modeled clear day. This course is almost linear with increasing tendency, considering that modeled period of time is 12am up to 1pm with sampling frequency 1 second. Course of FVE1 characterized the cloudy weather and therefore the supplied active power from those gathered plants was not linear growing as the FVE2. This course was influenced by cloud shifting that we set in simulating program. We can set there three types of cloud shifting with different shift that depend on regions. From this course is obvious that PV power plants have very variable production during the day exceptionally cloudy days cause fluctuation of supplied active power to the system. There are significant problems the regulation of active power in the system. The proportion of the production from PV power plants has a direct impact on the volume of support services and therefore for the regulation reserve on conventional energy resources. Although we increase the installed capacity in the power system and ensure the higher proportion of RES in the system, but the system stability of the system can be threatened [2].

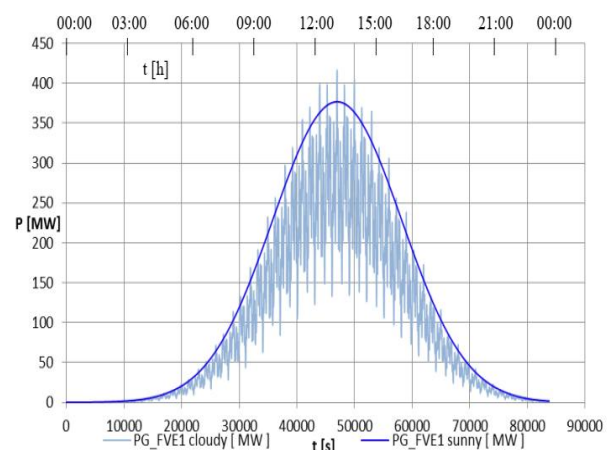

Fig. 3. Comparison of generation from PV during cloudy (FVE1) and sunny days (FVE2).

Fig. 3 shows the difference between supplied active power from FVE throughout the whole day with sampling frequency one second. There are modelled sunny and cloudy climate conditions. In TABLE I. we can see calculated difference in percentage between cloudy and sunny days modelled on PV power plants [2].

Table 1: Comparison Of Supplied Active Power

|                 | SUNNY DAY | CLOUDY DAY | DIFFERENCE | DIFFERENCE IN % |
|-----------------|-----------|------------|------------|-----------------|
| ELECTRIC ENERGY | 2939,35   | 2133,26    | 803,09     | 27,36 %         |

**B. Comparison of wind power plants**

Wind power plants also reflect to the fluctuations of supplied active power to the system. In this part of an article we deal with comparing two different parameters of wind intensity and variability that are the main reason of unpredictability of that RES.

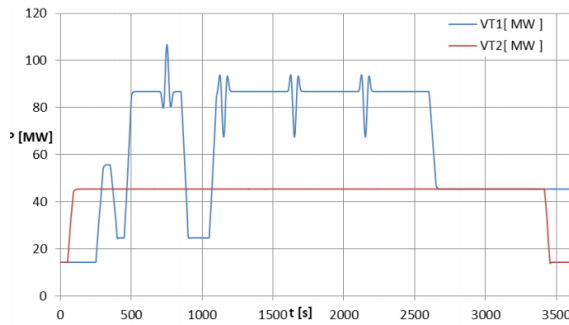

Fig. 4. Comparison of generation from wind turbines with gusts of wind and slight breeze.

There is on Fig. 3 a comparison of wind farms in two different areas with various climate conditions. We can set different parameters for wind turbine such as wind gusts or slight breeze in source parameters table for model in simulating program. VT1 changed the values of supplied active power due to the gusts of wind. These values are very difficult to predict and usually cause the problem with maintaining the balance between production and consumption in the power system. Another important problem is changing of active power flows in areas where the high concentration of wind power plants is. These changes can cause significant excess of power in the area where the proportion of RES is very high. Variable supply from renewable sources can also cause outages on power lines that are caused by overloading them and various short circuits and interruptions caused by occasional increases of supplies from these sources.

**C. Simulating the outage of transformer T103**

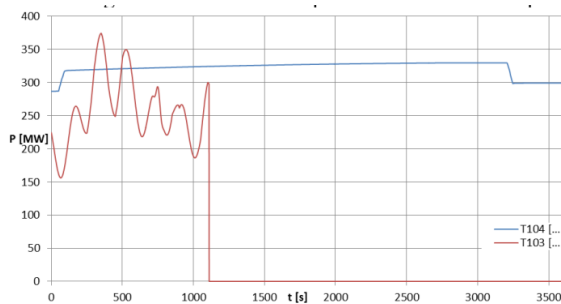

Fig. 5. Outage of transformer T103 due to overload.

The rapid increase in production of active power from VT1 causes the reackdown of the transformer T103. Transformer failure caused by the overload and then the disconnection by the protection, disable FVE1 and VT1 see Fig. 5. Such outage of transformer is very threatened to the system because it cause the outage of whole part of system with installed RES too. At the same time it brings the huge lack of sufficient active power for regulation. We need to have enough amount of active

power in tertiary regulation what means the power reserved on conventional energy sources for eventual maintaining the balance between production and consumption.

This failure causes a significant lack of active power in the power system and thus decreases the frequency of the system, as shown on Fig. 6.

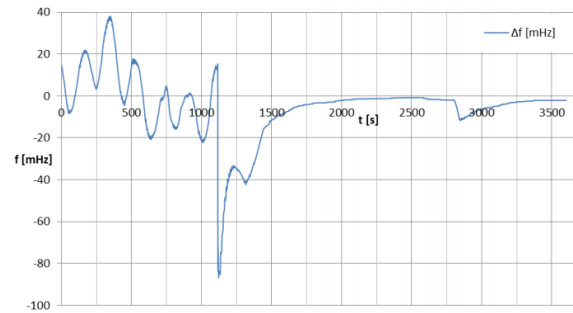

Fig.6 Frequency deviation during the outage of transformer.

The significant effect of variability supply of active power from RES can be observed on the course of frequency deviation from the nominal value, where due to cloud shifting on FVE occur fluctuations in performance and increasing in frequency deviation. At the time when there is an outage of transformer it causes the significant reduction in the frequency. The secondary regulation of active power takes control over the imbalance and regulate it to the required value.

**CONCLUSION**

Simulation of renewable energy sources confirmed that their difficulty of predictability and variability of supply may rise the frequency deviations in the power systems and thus an imbalance between production and consumption in the power system. Due to the large fluctuations of the active power supplied from renewable energy sources, there is the risk of sudden outage of those resources. Installation of photovoltaic resources get the total installed capacity in the system greater but the peak of energy consumption and the peak of production occur at different times. As far the proportion of the energy mix of sources exceeds a certain threshold encountered problems with maintaining a balance of power and thus the reliability of electricity supply will be threatened. For further expansion of the power system with new renewable, there is the possibility of using intelligent networks (Smart Grids), which become part of our daily lives. These power grids facilitate the management, regulation of production and consumption of electricity in real time. New modern power grids offers on the basis of smart metering detailed information about the power grid in real time, rapid analysis of failures and also offer the ability to connect large quantities of RES to the power grid.

**References**

- [1] Dudiak J., et al.:Vplyv obnoviteľných zdrojov elektrickej energie naelektrizačnú sústavu, In: Proceedings of the 7th International Scientific Symposium on Electrical Power Engineering: lektroenergetika 2013, Stará Lesná. - Košice : TU, FEI, 2013. 583s. ISBN 978-80-553-1441-9.
- [2] Dudiak J., Hocko P.: The Impact of Photovoltaic Power Plant on the Power System, In: 13th Scientific Conference of Young Researchers: Herľany, Slovakia. - Košice : TU, 2013, 419 - 422.s, ISBN 978-80-553-1422-8.
- [3] Veleba J.,Martinek Z.: Flicker Perceptibility Analysis for Photovoltaic Power Sources in Distribution

- Networks. Proceeding of the 12<sup>th</sup> International Scientific Conference Electric Power Engineering, 2011, p: Proceeding of the 13th International Scientific Conference Electric Power Engineering, Vols 1 and 2, Brno May 2012, p: 376-379.
- [4] Jiricka J., Tesarova M.: Determination of Coincidence Factors for PV Plant Generation Depending on Constancy of Sun Exposure. Proceeding of the 13th International Scientific Conference Electric Power Engineering, Vols 1 and 2, Brno May 2012, p: 469-474.
- [5] Kralovcova V., Martinek Z.: Evaluation of photovoltaic power plant. Proceeding of the 13th International Scientific Conference Electric Power Engineering, Vols 1 and 2, Brno May 2012, p: 535-538.
- [6] Dudiak J.: Modelovanie podporných služieb v programe MODES. Diploma thesis. Košice: Technical University of Košice, 2013, 73s. Kolcun M., et al.: Prevádzka elektrizačnej sústavy. Košice: TUKE, 2007. 306 s. ISBN 978-80-8073-837-2.
- [7] Kučerová A.: Numerická integrace lichoběžníkovou metodou[online]. Praha: CVUT, SFV, 2012 [citované 5. 12. 2012].
- [8] Maslo K.: Maintaining power balance in a system with renewable energy sources.
- [9] Maslo K.: Long – term dynamic modeling of renewable energy sources.